



Installation and Setup guide

Clavister SG5500 Series

Clavister AB
Torggatan 10
SE-891 28 Örnsköldsvik
SWEDEN

Phone: +46-660-299200
Fax: +46-660-12250

www.clavister.com

Build: 890
Published 2007-10-26
Copyright © 2007 Clavister AB

Installation and Setup guide Clavister SG5500 Series

Published 2007-10-26
Build: 890

Copyright © 2007 Clavister AB

Copyright Notice

This publication, including all photographs, illustrations and software, is protected under international copyright laws, with all rights reserved. Neither this manual, nor any of the material contained herein, may be reproduced without written consent of the author.

Disclaimer

The information in this document is subject to change without notice. The manufacturer makes no representations or warranties with respect to the contents hereof and specifically disclaim any implied warranties of merchantability or fitness for any particular purpose. The manufacturer reserves the right to revise this publication and to make changes from time to time in the content hereof without obligation of the manufacturer to notify any person of such revision or changes.

Limitations of Liability

UNDER NO CIRCUMSTANCES SHALL CLAVISTER OR ITS SUPPLIERS BE LIABLE FOR DAMAGES OF ANY CHARACTER (E.G. DAMAGES FOR LOSS OF PROFIT, SOFTWARE RESTORATION, WORK STOPPAGE, LOSS OF SAVED DATA OR ANY OTHER COMMERCIAL DAMAGES OR LOSSES) RESULTING FROM THE APPLICATION OR IMPROPER USE OF THE CLAVISTER PRODUCT OR FAILURE OF THE PRODUCT, EVEN IF CLAVISTER IS INFORMED OF THE POSSIBILITY OF SUCH DAMAGES. FURTHERMORE, CLAVISTER WILL NOT BE LIABLE FOR THIRD-PARTY CLAIMS AGAINST CUSTOMER FOR LOSSES OR DAMAGES. CLAVISTER WILL IN NO EVENT BE LIABLE FOR ANY DAMAGES IN EXCESS OF THE AMOUNT CLAVISTER RECEIVED FROM THE END-USER FOR THE PRODUCT.

Table of Contents

Preface	5
1. Important Information	6
2. Product Overview	8
3. Unpacking	9
4. Hardware Components	10
4.1. Front Layout	10
4.1.1. Secure Blade Modules	10
4.2. Rear Layout	13
4.2.1. Chassis Management Modules	14
4.2.2. Rear Transition Modules	17
5. Installation	20
5.1. Choosing a Suitable Environment	20
5.2. Setting up the Environment	21
5.3. Attaching Mounting Rails	23
5.4. Installing SBMs	25
5.5. Setting Chassis ID	26
5.6. Chassis Daisy chaining	27
6. Turning on Power	30
7. CorePlus Console Setup	32
7.1. Configuring CorePlus	32
7.2. Finalizing the Configuration	34
8. The CMM Web-Interface	36
8.1. Chassis Remote Management	36
8.2. The Health Monitor	37
8.3. Hardware Control	40
8.4. Version Information	43
8.5. System Administration	45
8.6. Account Management	50
9. Hot-Swapping Components	53
9.1. Hot-Swapping Secure Blade Modules	53
9.2. Hot-Swapping PSUs	55
9.3. CMM and RTM Hot-Swapping	57
9.4. CFT Hot-Swapping	58
10. Safety Advisory	60
10.1. Safety Information	60
10.2. Wichtige Information zur Sicherheit Sicherheitshinweise	62
11. Hardware Specifications	65
A. SNMP Examples	66
Alphabetical Index	68

List of Figures

3.1. Unpacking the SG5500 Series	9
4.1. SG5500 Series front view	10
4.2. A Secure Blade Module (SBM)	10
4.3. SBM ports, buttons and LEDs	11
4.4. Key to SBM ports, buttons and LEDs	11
4.5. SG5500 Series rear view schematic	13
4.6. AC Power Supplies	13
4.7. Power Supply Units and power inlets	14
4.8. Cooling Fan Trays	14
4.9. A Chassis Management Module (CMM)	14
4.10. Chassis Management Module slots	15
4.11. Chassis Management Module detail	15
4.12. Management connection ports	16
4.13. A Rear Transition Module (RTM)	17
4.14. RTM expansion slots	17
4.15. RTM interface mapping	18
5.1. Setting Chassis ID	26
5.2. Two Daisychaining schemes	27
5.3. Daisychain cabling	28
6.1. Turning on power	30
6.2. A UPS unit	31
6.3. A power strip	31
8.1. CMM Web-Interface login	36
8.2. Chassis Status	37
8.3. SBM Status webpage	38
8.4. SBM Status color indicators	38
8.5. Alert Settings page	39
8.6. SBM Control page	40
8.7. Chassis Control page	41
8.8. PSU Control	41
8.9. SBM Version information	43
8.10. Chassis Version information	44
8.11. Chassis Settings Information	45
8.12. Network Settings	46
8.13. Alert Notification	46
8.14. Firmware Update	47
8.15. Select firmware file	47
8.16. Select binary firmware file	47
8.17. Start firmware upgrade	48
8.18. Upgrade firmware progress bar	48
8.19. Account Management page	50
8.20. Defining a Web-Interface account	51
8.21. Changing an Account Password	51
9.1. SBM Hot-Swapping	53
9.2. A Power Supply Unit (PSU)	55
9.3. PSU Hot-Swapping	55
9.4. Removing a PSU	56
9.5. Blade locking levers	57
9.6. A Cooling Fan Tray (CFT)	58
9.7. Cooling Fan Tray Hot-Swapping	58
11.1. Dimensions and Weight	65
11.2. Regulatory and Safety Standards	65
11.3. Environmental	65

Preface

Target Audience

The target audience for this guide is the user who has taken delivery of a packaged Clavister SG5500 Series Security Gateway appliance. The guide takes the user from unpacking and installation of the device through to power-up and initial network connection.

Abbreviations

Abbreviations used in this manual for SG5500 Series components are:

CFT - Cooling Fan Tray
CMM - Chassis Management Module
KVM - Keyboard, Video, Mouse
PSU - Power Supply Unit
RTM - Rear Transition Module
SBM - Secure Blade Module

Notes to the main text

Special sections of text which the reader should pay special attention to are indicated by icons on the left hand side of the page followed by a short paragraph in italicized text. There are the following types of such sections:



Note

This indicates some piece of information that is an addition to the preceding text. It may concern something that is being emphasised or something that is not obvious or explicitly stated in the preceding text.



Tip

This indicates a piece of non-critical information that is useful to know in certain situations but is not essential reading.



Caution

This indicates where the reader should be careful with their actions as an undesirable situation may result if care is not exercised.



Important

This is an essential point that the reader should read and understand.



Warning

This is essential reading for the user as they should be aware that a serious situation may result if certain actions are taken or not taken.

Chapter 1. Important Information

Power Supply Warning

Turning off the power switch does not turn off power to the entire Clavister SG5500 Series appliance. Disconnect the system from its power source and from any telecommunications links, networks, or modems before performing any of the procedures described in this guide with the exception of hot-swapping. Failure to do this can result in personal injury or equipment damage. Some circuitry in the appliance will continue to operate even though the power switch is off. This guide is intended for qualified technical personnel with experience of installing and configuring network equipment. Read and adhere to all warnings, cautions, and notices in this guide and the documentation supplied with the chassis, power supply, and accessory modules. If the instructions for the chassis and power supply are inconsistent with these instructions, or the instructions for accessory modules, contact the supplier to find out how you can ensure that your system meets all safety and regulatory requirements.

Electrostatic Discharge Caution

Electrostatic discharge (ESD) can damage server components. Do the described procedures only at an ESD workstation. If no such station is available, you can provide some ESD protection by wearing an anti-static wrist strap and grounding it to a metal part of the computer chassis.

Inadequate Power Notice

The system has an auto-switch power supply from 100V to 240V; however the system may shutdown because of inadequate power input level and quality.

Intended Use Notice

This product was evaluated for use in computer rack cabinets within computer rooms and similar locations. Other uses may require further evaluation.

Safety Compliance

The equipment is CB, UL and TÜV approved. A complete, updated compliance list is maintained at <http://www.clavister.com>

Declaration of FCC Conformity

This appliance has been tested and verified to comply with Class B limits when configured into a compatible host computer, pursuant to FCC Rules. These limits are designed to provide reasonable protection against harmful interference in a residential installation. This equipment generates, uses, and can radiate radio frequency energy and, if not installed and used in accordance with the instructions, may cause harmful interference to radio communications. However, there is no guarantee that interference will not occur in a particular installation.

The appliance complies with part 15 of FCC rules. Operation is subject to the following conditions:

- This device may not cause harmful interference
- This device must accept any interference received, including interference that may cause undesired operation.

A complete, updated conformity list is maintained at <http://www.clavister.com>

To ensure EMC compliance with your local regional rules and regulations, the final configuration of

your final configuration may require additional EMC compliance testing. For more information, please contact your local Clavister representative.

***Important***

Further important safety advisory information is to be found in English and German at the end of this publication in Chapter 10, Safety Advisory. Ket hardware specifications can be found in Chapter 11, Hardware Specifications.

Chapter 2. Product Overview



The Clavister SG5500 Series is a high performing, modular, chassis based security gateway appliance designed for the unique requirements of performance critical environments such as the telecom industry, service providers, the financial sector and data centers.

The SG5500 Series is a chassis based system. A single SG5500 Series device chassis is capable of maintaining up to:

- 8 x Secure Blade Modules (SBMs)
- 7 x Hot-swappable Power Supply Units (PSUs)
- 4 x Cooling Fan Trays (CFTs)
- 2 x Rear Transition Modules (RTMs)
- 2 x Chassis Management Modules (CMMs) for out-of-band chassis management

Secure Blade Modules

A single SG5500 Series chassis can contain multiple Secure Blade Modules (SBMs). Each SBM acts as a single, autonomous Clavister Security Gateway. Like any Clavister device, each blade has an RS232 serial port connection which allows connection of a console to the gateway for initial configuration. A console need only be connected however to the RS232 port on the Chassis Management Module (CMM) since this can be switched between different SBMs. Switching the KVM port between SBMs is done manually by pressing the KVM button on the SBM or by selecting the SBM for KVM access through the Chassis Management Module Web-Interface.

Chassis Management

Out-of-band management of SG5500 Series hardware is done via the Chassis Management Module (CMM). Communication with the CMM is achieved through the CMM Web-Interface. This allows comprehensive monitoring of operational parameters such as temperature, fan speed and component failure.

The hardware management of the SG5500 Series via the CMM is totally separate from the security gateway functions of the SBMs. There is no interaction between the CMM and the management of CorePlus security gateway functions, which are managed using the Clavister FineTune software tool.



Note

Daisy chaining of multiple SG5500 Series chassis is possible and is done for the purpose of management control of multiple systems from a single KVM workstation.

Chapter 3. Unpacking

The Clavister SG5500 Series comes securely packaged in a sturdy cardboard shipping carton and a wood re-enforced casing. Upon receiving the appliance, unscrew the casing's top frame, open the carton and carefully remove the contents. If anything is missing or damaged, please contact your reseller immediately. The shipping carton should contain the following items:

- An SG5500 Series Chassis with:
 - 1 x Chassis Management Module
 - 7 x Power Supply Modules
 - 4 x Chassis Cooling Fan Trays
 - 2 x Rear Transition Modules
 - Cover plates for all Secure Blade Module slots
- An SG5500 Series accessory kit containing:
 - Three power cords
 - One KVM adapter cable for connection of PS/2 keyboard, VGA monitor and mouse to the Chassis Management Module
 - One 50 pin micro d-sub to serial console adapter cable for connection to the SBM front combo port
 - One Chassis Management Module RJ45 to serial console adapter cable
 - Mounting Rails

Figure 3.1. Unpacking the SG5500 Series

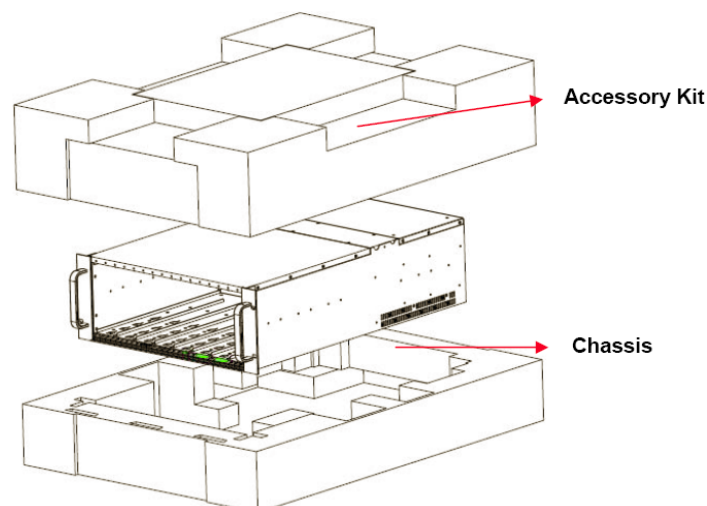

Note

Do not throw away the packaging materials. They may be needed again for future shipping.

Chapter 4. Hardware Components

- Front Layout, page 10
- Rear Layout, page 13

This chapter describes the hardware components of an SG5500 Series appliance.

4.1. Front Layout

Figure 4.1. SG5500 Series front view



The figure above shows the front of the SG5500 Series chassis with 8 Secure Blade Modules installed:

4.1.1. Secure Blade Modules

A Secure Blade Module (SBM) performs the security gateway processing functions of the SG5500 Series. The basic SG5500 Series chassis is not delivered with any SBMs, and these should be ordered separately. SBMs come with a CD-ROM for Clavister software installation.

Figure 4.2. A Secure Blade Module (SBM)



Figure 4.3. SBM ports, buttons and LEDs

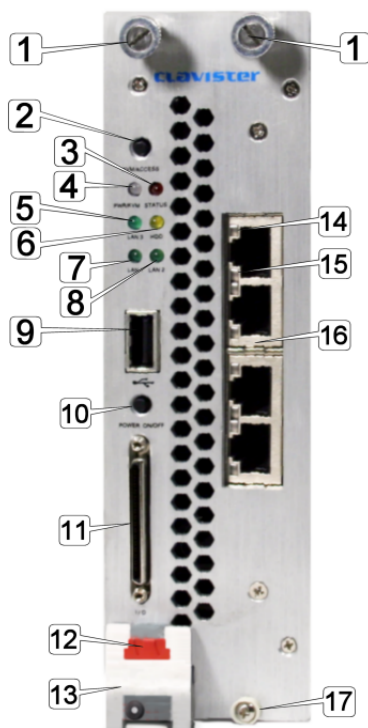

Figure 4.4. Key to SBM ports, buttons and LEDs

No.	Description	Function
1	Locking Screws	Secures the SBM to the chassis.
2	KVM access button	Press to obtain KVM and serial console access to this blade via the CMM access port.
3	Status LED	Red indicates a system fault.
4	PWR/KVM LED	Blue indicates the SBM is powered on Green indicates this SBM is selected for KVM and serial console access.
5	LAN3 LED	Indicator for the cmm interface.
6	HDD LED	Indicates firmware loading activity.
7	LAN1 LED	Indicator for the ge1 interface.
8	LAN2 LED	Indicator for the ge2 interface.
9	USB port	Supports USB v2.0 (not required for normal operation).
10	Power button	Turns SBM Off and On. Press and hold for 5 seconds to power Off.
11	Combo I/O port	Allows KVM and serial console connection.
12	Release safety	Red release safety button used when removing an SBM.
13	Release lever	The main release lever for the SBM.
14	Activity LED	Shows CGE port activity.
15	Link status	Shows CGE port link status.
16	CGE ports	4 x Crypto Gigabit Ethernet ports with CorePlus logical names cge1 , cge2 , cge3 and cge4 (2 additional Gigabit ports can connect from the SBM's rear through the RTMs)
17	Safety locking screw	An additional screw which holds the SBM.

SBM slot positions

Each SBM corresponds to a single, autonomous Clavister Security Gateway. The chassis can accommodate from 1 to 8 SBMs. SBMs must always be placed in odd-numbered slots but it does not matter which odd-numbered slots are used when there is less than 8 blades. It is recommended, however, that the physical space around blades in a sparsely populated chassis is maximized in order to maximize air-flow and to minimize potential hot-spots.

Adding additional SBMs

Additional SBMs can be added to a operating SG5500 Series chassis without disturbing the operation of the SBMs already installed. Extreme care should be taken however, not to physically disturb the existing SBMs.

SBM Link Speed

Each SBM is equipped with 4 NITROX II secure network interfaces and 2 additional network interfaces at the RTM side. All 6 interfaces are designed for 1000BaseT links only and this is the speed at which they should be used. **100BaseT should never be used.**

100BaseT Known Issues

100BaseT won't function at all with the 2 ports connected to the RTM. In the case of the 4 NITROX II interfaces 100BaseT could be used but this creates a number of known issues. The first issue is that it takes a long period of time to initially autonegotiate the link. In some cases this can be up to 60 seconds. The second issue is that if there is a need to later renegotiate the link because of, for example a re-boot, the link may not re-establish at all. 100BaseT should not therefore be used.

4.2. Rear Layout

Figure 4.5. SG5500 Series rear view schematic

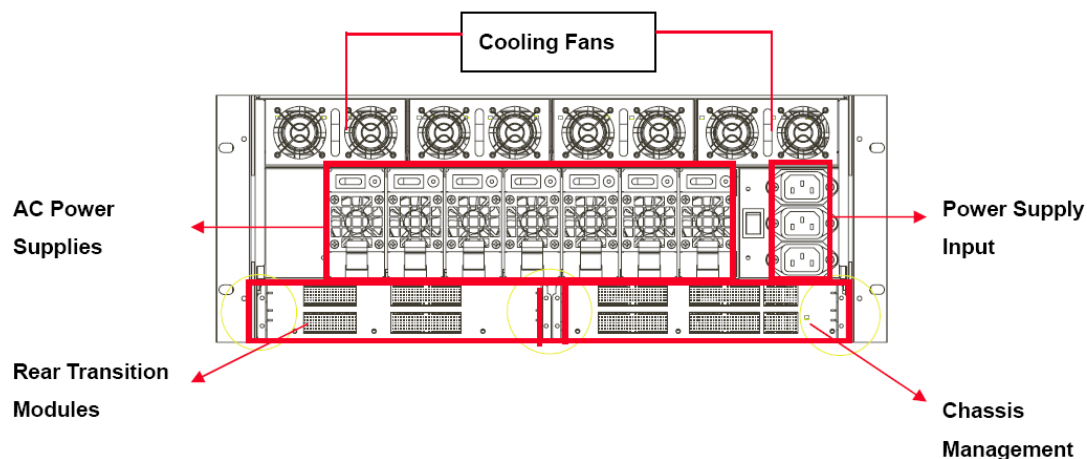

The structure at the rear of the SG5500 Series chassis is made up of:

- 4 x hot-swappable Cooling Fan Trays, each housing 2 fans
- 7 x AC Power Supply Units
- Chassis Management Modules. Only 1 CMM comes as standard and this is sufficient for most purposes. A second CMM is needed only for special configurations and is not normally required.
- Rear Transition Modules
 - The upper module supports the **ge1** port on the Secure Blade Module(s)
 - The lower module supports the **ge2** port on the Secure Blade Module(s)

Figure 4.6. AC Power Supplies

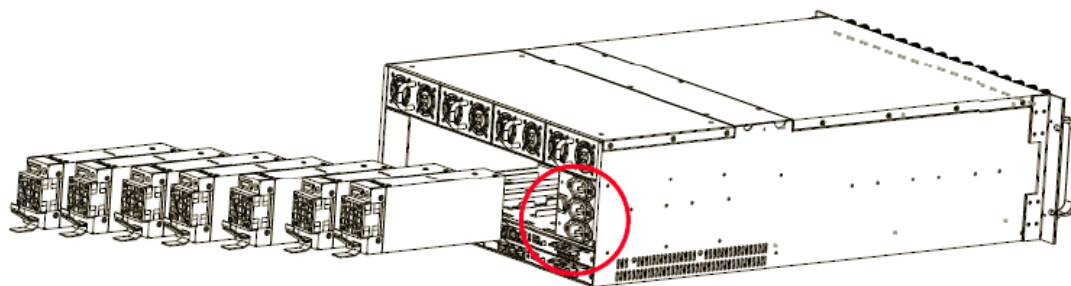

Figure 4.7. Power Supply Units and power inlets

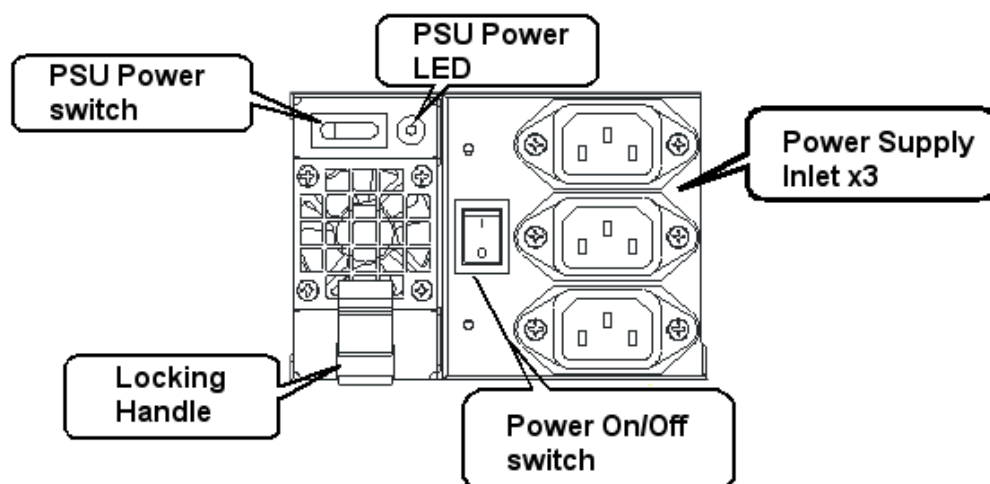
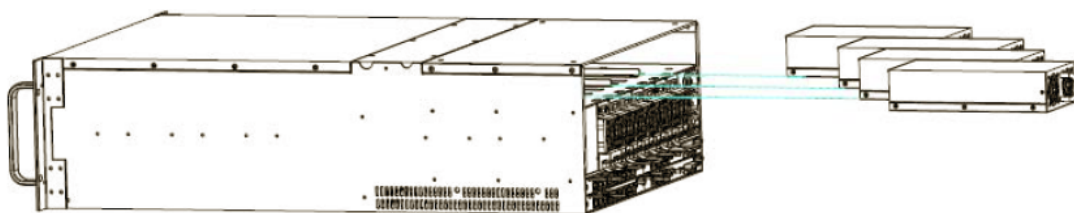

Figure 4.8. Cooling Fan Trays



4.2.1. Chassis Management Modules

Figure 4.9. A Chassis Management Module (CMM)



A Chassis Management Module (CMM) provides out-of-band management for the chassis and the Secure Blade Modules. Most configurations require only one CMM per chassis.

Figure 4.10. Chassis Management Module slots

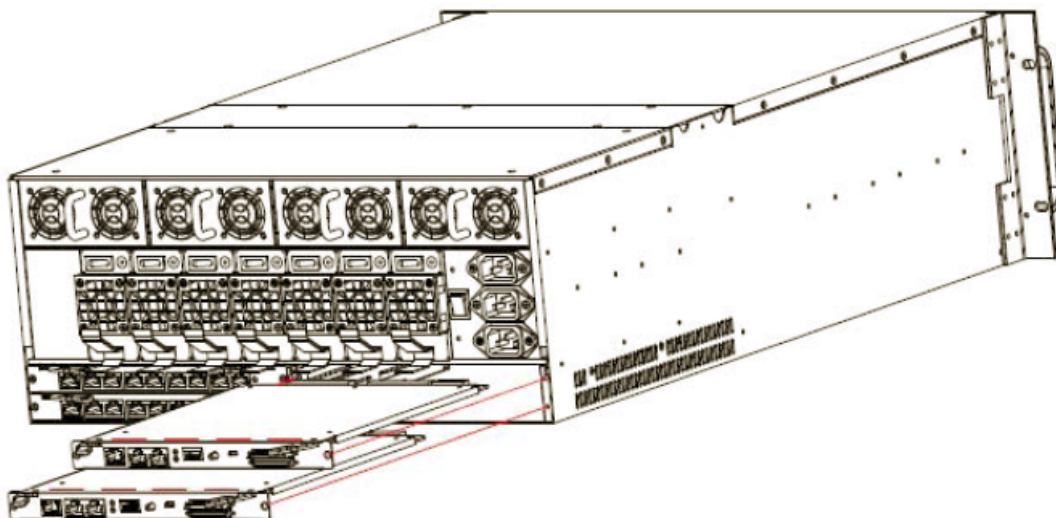
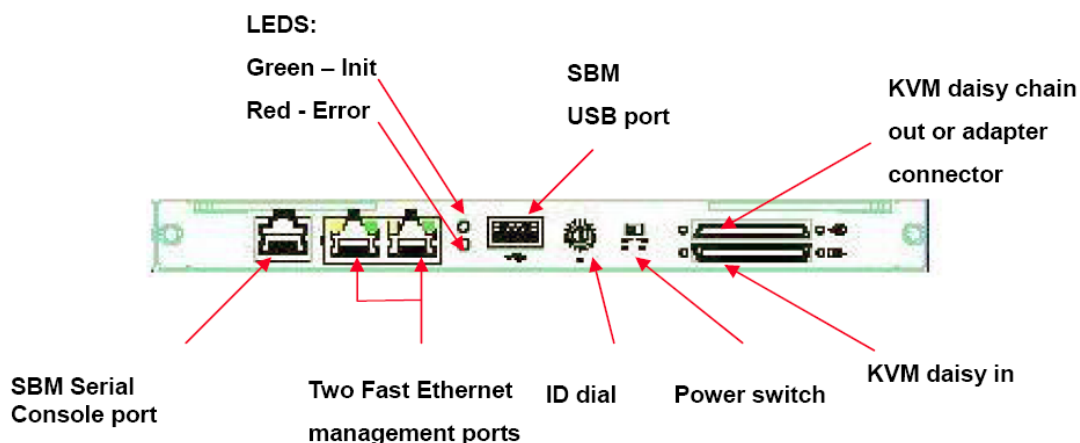

Figure 4.11. Chassis Management Module detail



The Chassis Management Module contains:

Keyboard, Video, Mouse (KVM) and Daisy Chain connectors These connectors are used for KVM cable connectors or for the connector used for daisy chaining multiple CMMs.

Power switch Use this switch to turn the Chassis Management Module on and off.

Chassis ID dial This dial defines the ID of each chassis. The Chassis ID is used for identifying each unique chassis in a daisy chain setup. The dial on the master chassis must be set to 0. The remaining chassis IDs can have any number provided all numbers are unique (using consecutive numbers is recommended). Chassis ID duplication is not allowed in a multi-chassis installation.

WARNING: The ID **MUST BE SET TO "0"** in a single chassis system for correct operation.

USB port	This USB port is connected to the USB port on the SBM which is currently being managed by the Chassis Management Module.
ERR LED light	Indicates a system fault.
Code Init LED	Flashing indicates a management boot sequence is in progress. When this LED is lit continuously it indicates initialization is complete
LAN port	2 x 10/100 Mbit interfaces which can be used for remote management.
Serial port	This serial port is connected directly to the SBM which is currently being managed by the Chassis Management Module.

Out-of-band management is performed in two ways using the Web-Interface which accesses the CMM via the LAN1 and LAN2 Ethernet ports.

Web-interface functions include:

- Web Pages for managing blades and chassis
- Email report status
- SBM Health monitor (CPU core voltage, fan and temp)
- Administrator login authentication
- Chassis health monitor
- SBM status reports
- Power On, Off and Restart
- Boot device switching
- IP configuration

All Secure Blade Modules have a CorePlus logical **cmm** management interface which is connected to an internal Fast Ethernet switch on the Chassis Management Module and is accessible through the Chassis Management Module ports marked LAN1 and LAN2. Management using the Web-Interface is available via Ethernet connections to these ports. The 100 Mb switch fabric of the CMM means that SBMs can use this to communicate with each other.

Figure 4.12. Management connection ports



4.2.2. Rear Transition Modules

Figure 4.13. A Rear Transition Module (RTM)

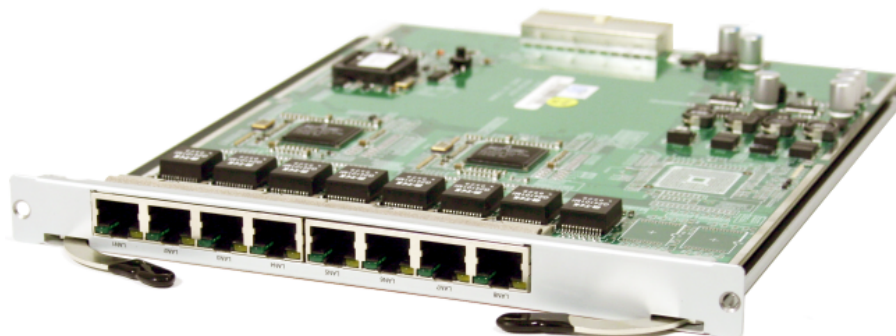

The purpose of the Rear Transition Module (RTM) is to provide additional Ethernet connectivity to the 2 interfaces, **ge1** and **ge2**, on the back of each Secure Blade Module. One port on each RTM is directly connected to one of the physical GE interfaces on the Secure Blade Modules. The upper module connects to all SBM **ge1** interfaces. The lower one connects to all SBM **ge2** interfaces.

Figure 4.14. RTM expansion slots

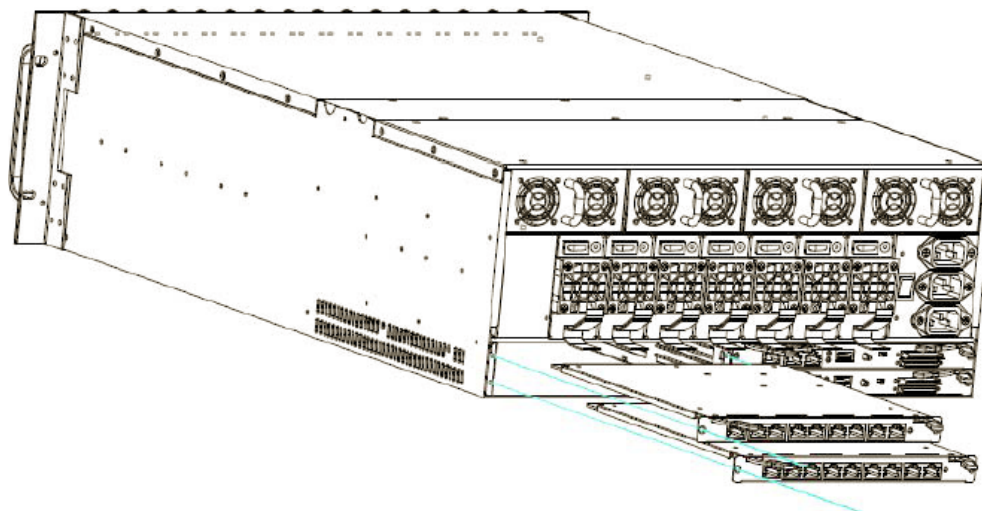

Physical interfaces on an RTM are labeled LAN1 to LAN8 from right to left. As shown in the illustration below, LAN1 is physically connected to Blade A, LAN2 to Blade B, LAN3 to Blade C and so on. (The standard RTM does not implement a switch fabric and if this is required you should contact your SG5500 Series supplier about RTM alternatives).



A Recap of SBM to RTM Connections

When using two Rear Transition Modules, each SBM can provide a total of 6 x Gigabit Ethernet ports. There are 4 on the front of the SBM and 2 others at the back.

*The 2 ports at the back are accessible via the RTMs, the top port through the upper RTM and the bottom port through the lower RTM. All the SBM top **ge1** ports connect to the top RTM and all the lower **ge2** ports connect to the bottom RTM.*

Figure 4.15. RTM interface mapping

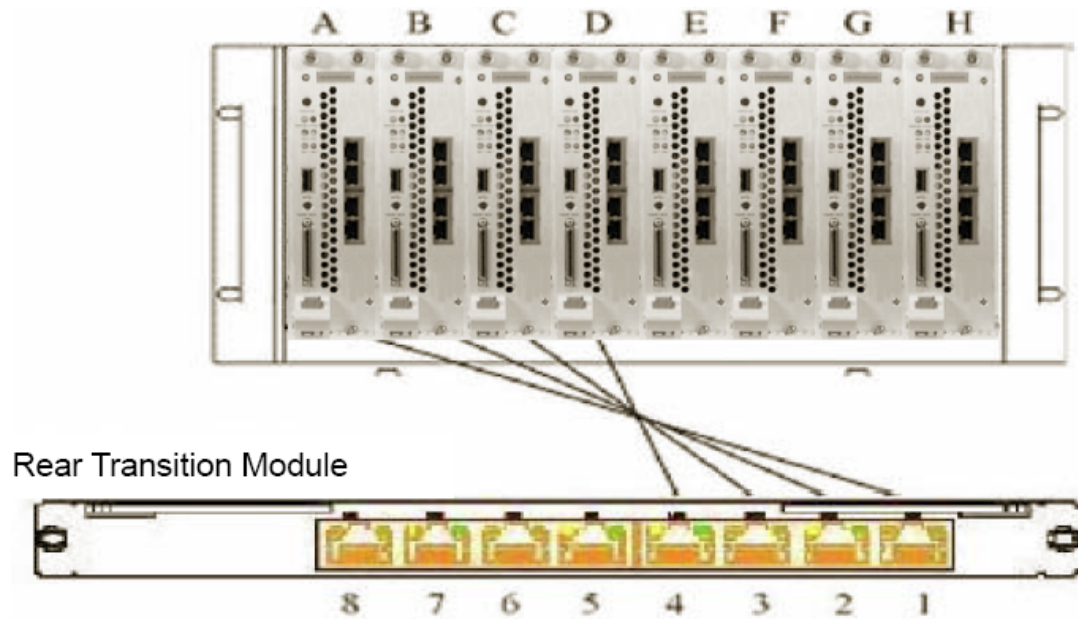
**Important**

The Rear Transition Module RJ45 ports are ONLY capable of 1000BaseT full duplex and should not be connected in any other way.

Chapter 5. Installation

- Choosing a Suitable Environment, page 20
- Setting up the Environment, page 21
- Attaching Mounting Rails, page 23
- Installing SBMs, page 25
- Setting Chassis ID, page 26
- Chassis Daisy chaining, page 27

This section provides information for the correct physical installation of an SG5500 Series appliance. Please read all the safety information in this document before continuing. These guidelines will help you work safely while setting up the hardware.

5.1. Choosing a Suitable Environment

The SG5500 Series can operate under a wide range of environmental conditions. However, to ensure a prolonged lifetime and continued high performance, consider the following factors when setting up your system:

- Set the system on a flat, stable surface or in a suitable rack (soft feet are attached to the underside of the SG5500 Series for surface mounting). To prevent damage to the system, avoid environments where the device will be exposed to strong vibration.
- Place the device away from electromagnetic or radio frequency interference (for example: television or stereo sets, copying machines and air conditioners).
- Avoid using or storing the SG5500 Series where it will be exposed to extreme temperatures. In particular, do not leave the system in direct sunlight, over a radiator, or near a heat source for a long period. High temperatures can damage the circuitry.
- Avoid exposing the device to high or low humidity. Extreme humidity can contribute to hardware failure.
- Do not allow anything to rest on the power cord. Do not place the system where people can step on or trip over the cables or power cords.

For detailed information on suitable operating temperatures and humidity, please see Chapter 11, *Hardware Specifications*.

5.2. Setting up the Environment

Choosing a Rack

The Clavister SG5500 Series device may be mounted in a server rack. Installation in a rack and then organizing a dedicated server room offers many advantages. Computer server racks occupy a minimum of floor space while maximizing vertical space utilization. Racks also provide a safe and stable platform for computing equipment. Mounting all your computer and network equipment in a customized server rack and then centralizing the equipment in a single room makes for easy maintenance and access.

Two main types of server racks are available:

Open bay server racks

These racks are easy to customize, and can be expanded to accommodate many types of equipment storage applications. The open-bay server rack also provides easy access to hardware for maintenance and troubleshooting tasks.

These computer racks are more appropriate for secured server rooms, and are generally more affordable since they do not have side panels or lockable doors.

Enclosed computer cabinets

Enclosed computer cabinets provide better security than their open bay server rack counterparts. The enclosed computer cabinets prevent dust and contaminants from effecting the hardware.

A rack cabinet with a depth of more than 800 mm, excluding the front door depth, is recommended for the SG5500 Series. For better heat dissipation, the rear side of the rack cabinet should be open.

Server room layout

A well-designed server room provides enough space for rack furniture and computer equipment, and allows for future expansion. Ensure convenient access to cables and cable connections by leaving enough room around the server racks or cabinets. Network cables should be stored either in the ceiling or in the space under a raised floor to prevent tangles and provide a safe working area.

Provide storage space such as shelves to store instruction manuals, test equipment, software, and other necessary items. A desktop workspace provides extra convenience and utility to server room operators.

The SG5500 Series can reduce workstation clutter and avoid the necessity for multiple workstations by allowing a single Keyboard, Video, Mouse (KVM) combination to monitor all blades in a single SG5500 Series chassis. This done by connecting the KVM adaptor cable to the KVM port on the Chassis Management Module. The KVM cable can be daisychained for monitoring multiple chassis.

Managing cables

Labeled and color-coded cables simplify installation and troubleshooting and make cable identification easier. Most computer server racks provide some method of cable management, either through the use of cable raceways, metal loops, or closed cable channels. Nylon cable ties are also an effective way to gather loose cables and organize different wiring segments.

Securing the server room

Controlled access to the server room is important to protect your information and equipment.

Implement passwords on all systems, and have locked or card-access entry to all server rooms to reduce the risk of unauthorized intrusion. Using computer cabinets that have locks is also an effective deterrent against unauthorized access.

5.3. Attaching Mounting Rails

If a SG5500 Series chassis is to be rack mounted then it is important to use mounting rails since the large weight of a system, which is greater at the rear than the front, makes front only support impracticable. Mounting rails provide a convenient way of sliding the SG5500 Series chassis into a rack.

Mounting rails can not only provide sufficient support to the chassis rear but also mean that it can slide out from a rack mount shelf for easier maintenance.

Each side of the SG5500 Series chassis has 13 pre-drilled holes for mounting screws. The mounting rails supplied are generic mounting rails that have multiple pre-drilled screw holes. By aligning the appropriate holes in the mounting rails with three of the holes in each chassis side, it is possible to secure each rail to the chassis with 3 screws (6 in total). The rail bracket is attached using the chassis holes indicated as **1**, **2** and **3** in the image below.



The attachment procedure steps are described below for each of the two rails:

1. Detach the innermost bracket part of the rail for attachment to the chassis. Do this by extending the rail to its maximum extension and unlocking the latch that keeps the innermost bracket part secured (indicated as **4** in the image below). An engraved arrow (**5**) on the inner bracket metal indicates the direction the latch should be moved in order to disengage it. The outer, remaining part of the rail will be secured into the storage rack as explained later.

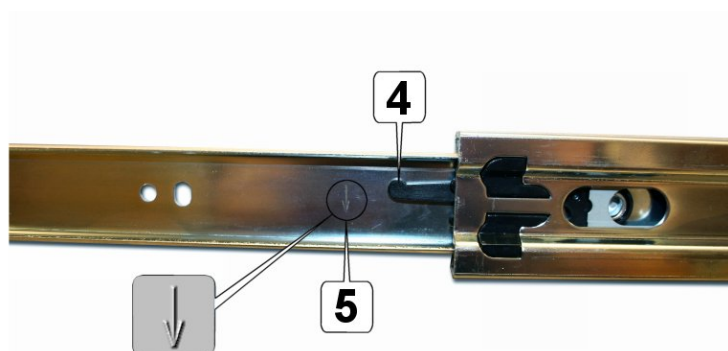

2. Line up the holes of the detached bracket with the holes on one side of the chassis. The front part of the bracket, which is located nearest the front of the chassis, has a 90 degree bend at one end, as shown in the picture below. The rear of the bracket nearest the rear of the chassis is flat, with a "U" shaped cut-out, as shown below.
3. To get alignment of the 3 holes, line up the last hole in the bracket (nearest the rear) to the last hole on the chassis (nearest the rear).
4. Using 3 of the flat-headed I4x4 screws supplied with the rail, securely attach the bracket to the chassis side using the three aligned holes, as shown below.

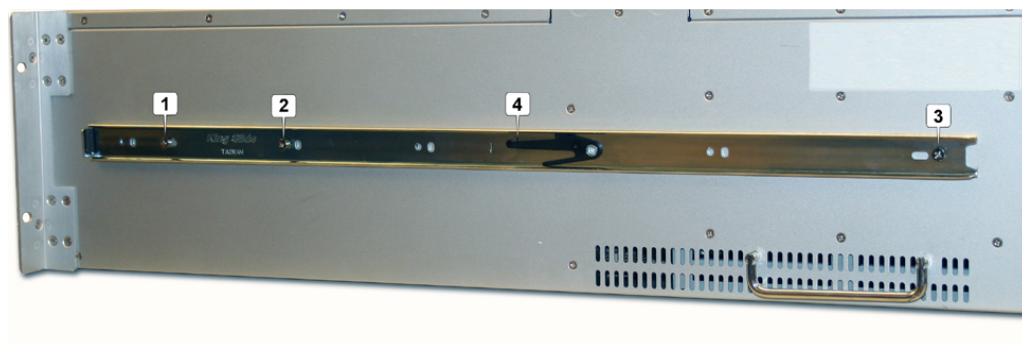

The order of inserting and securing the screws is important. It should be done as follows:

- Insert the first screw into the bracket's 4th hole from the front of the rail (**2** in the image above) and secure it loosely (this should correspond to the 4th hole from the front of the chassis).
 - Now insert a second screw loosely into the 3rd hole from the front of the bracket (**1** in the image above and corresponding to the 2nd hole from the front of the chassis).
 - Now insert the third screw loosely into last bracket hole nearest the back of the chassis (**3** in the image above and corresponding to the last hole in the chassis).
 - Starting with the middle screw, tighten the inserted screws so that all three screws are firmly in place and the bracket is securely fastened. The screw heads will fit almost flush with the bracket surface.
5. Repeat the above steps for the other rail and other side of the chassis.
 6. Attach the outermost rail part to the position in the rack where the chassis is to be mounted. Note that the length of these supporting rails can be adjusted to suit racks with different depths.
 7. Now slide the chassis into the rack so that the rail parts attached to the chassis re-engage with the corresponding rail parts secured in the rack. Be careful not to leave the chassis so that its front part is outside of the rack and unsupported.



Warning

THE RAILS ARE NOT DESIGNED TO SUPPORT THE ENTIRE CHASSIS WEIGHT WHEN SLIDING IT OUT FROM A RACK.

5.4. Installing SBMs

Secure Blade Modules (SBMs) are delivered and packaged separately from the SG5500 Series chassis.

To fit each SBM into the chassis:

1. First remove the covering plate to reveal the double slot location into which the SBM is to be fitted. Each covering plate has the same securing screw arrangement as the SBM itself, with 2 upper main screws and a single lower safety screw.
2. Slide the new SBM into the chassis holding the release lever down until the blade is locked into its connector again. Then gently pull the lever upwards again with one hand and press with the other hand on the top of the blade to make the red safety button snap into the locked position again.
3. Tighten the three screws, two upper and one lower safety, on the front panel to securely hold the SBM in place.

5.5. Setting Chassis ID

If multiple SG5500 Series chassis are to be daisy-chained for management purposes, a unique ID must be assigned to each chassis.

Note that in a single chassis configuration the **CHASSIS ID MUST BE SET TO "0"** for the system to operate correctly. (This should also be the ID already assigned to a newly unpacked chassis).

To change the chassis ID use a screwdriver to turn the ID dial on the CMM located in the primary module slot of the chassis as shown in the illustration below. The dial setting can range from 0 to 15. The ID of the master chassis in a daisy chain must be set to "0". The remaining chassis should be given a unique ID between 1 and 15. Using a sequential numbering scheme corresponding to the positions of the chassis in a rack is recommended.

Figure 5.1. Setting Chassis ID

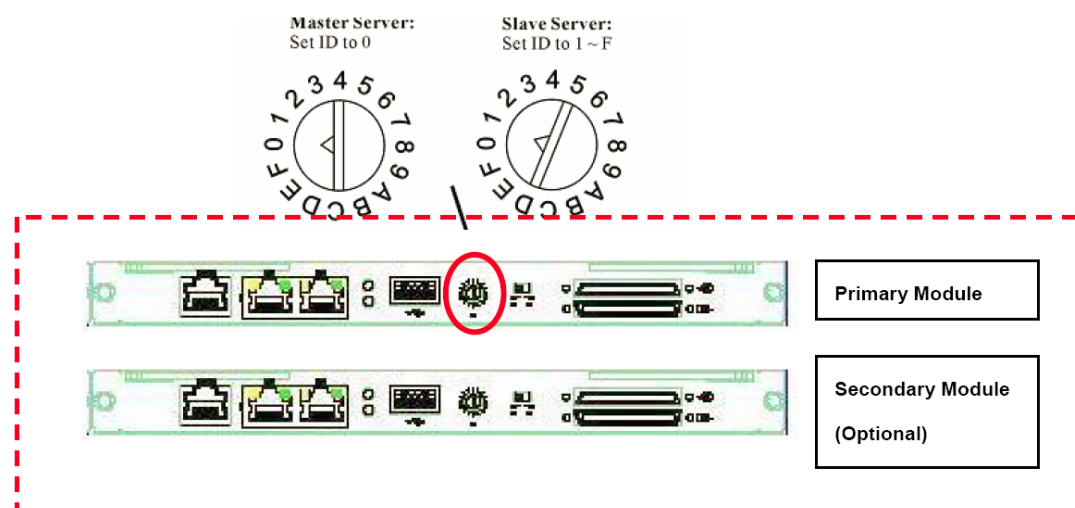

Note

When using the Clavister SG5500 Series device as a stand-alone system without daisy-chaining, check that the chassis ID is set to the factory default of "0".

5.6. Chassis Daisychaining

Daisychaining is a feature that frees up space and reduces cabling by allowing multiple SG5500 Series chassis to share a single keyboard, video, mouse (KVM) management workstation through a daisychained KVM cable.

Setting Daisy Chain IDs

To daisy chain together a number of SG5500 Series chassis, a unique ID number must first be allocated to each chassis. Assume all the chassis to be daisychained are mounted, one under the other, in a single rack. Using the instructions for setting chassis ID described above:

1. Set the master chassis ID at the top to "0".
2. Set the ID on the chassis below the master to "1".
3. Set the ID on the chassis below chassis "1" to "2".
4. Continue setting the IDs in this way until each chassis has a unique ID number.

The figure below shows the numbering scheme described above in "Case 2". "Case 1" shows an alternative scheme. Either can be used.

Figure 5.2. Two Daisychaining schemes

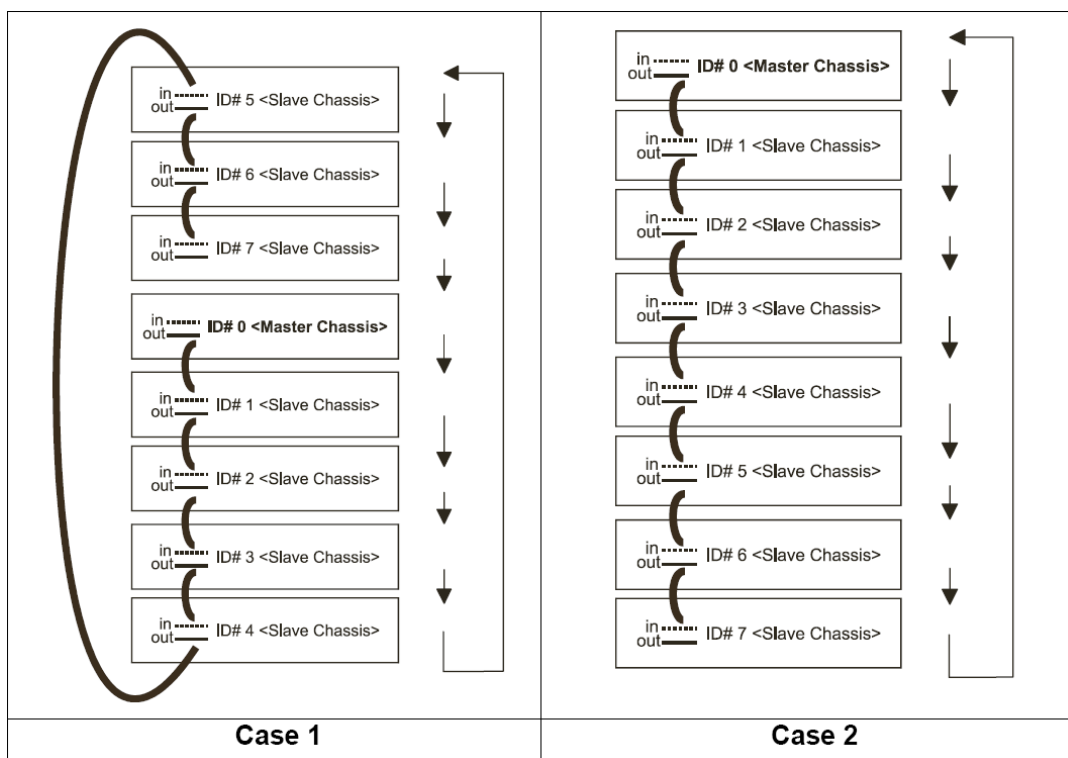

The connection steps in the next section are based upon "Case 2" and assume the chassis have consecutive numbering.

Connecting daisychain cables

1. Starting from the master chassis with ID "0", connect the KVM daisy chain cable female connector to the male input daisy chain port (marked with an arrow entering two circles) of the upper chassis.
2. Connect the male end of the KVM daisy chain cable to the female output daisy chain port of the lower chassis (marked with an arrow leaving two circles). This would have ID "1"
3. Repeat the steps above for the remaining chassis. The last chassis will not have the input port connected to anything.
4. Connect the KVM adapter cable to the female output connector on the top, master chassis for external keyboard, VGA and mouse.

Figure 5.3. Daisychain cabling

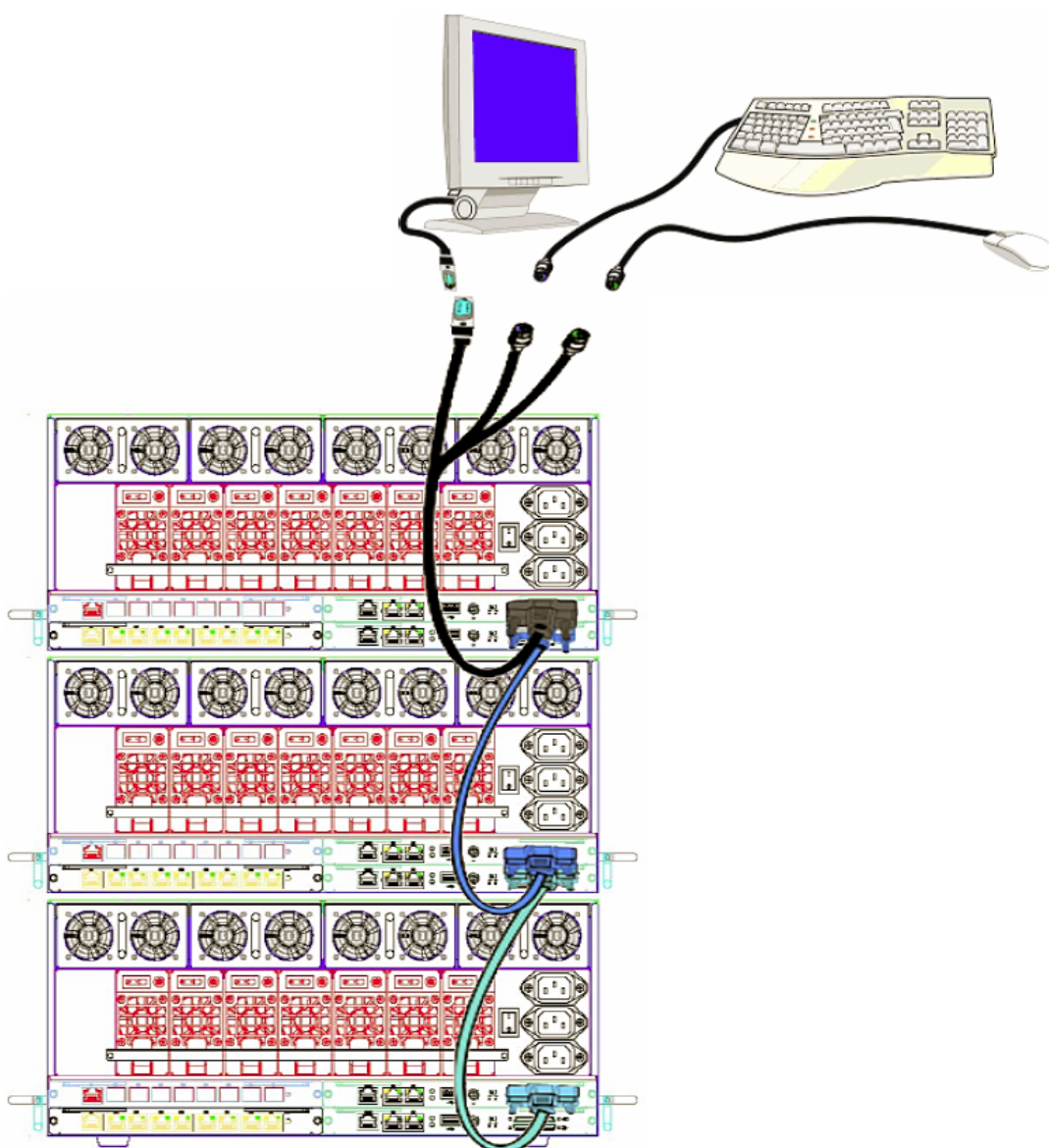

Chapter 6. Turning on Power



Important

Before turning on the SG5500 Series appliance, make sure you are familiar with the features of the device and have read through all safety information in this guide.

As shown below, the SG5500 Series chassis contains 7 power supply units (PSUs) fed by three power cables (labelled **1** below). Power cable **A** feeds power to the PSUs labelled **A**, cable **B** to PSUs **B** and cable **C** to PSUs **C**.

All PSUs are equal, and all contribute to overall chassis power. It is not however, necessary to have all PSUs operational if the chassis has only a few SBMs fitted. At minimum, there should be at least 3 PSUs operational, one for each power cable (one from each group **A**, **B** and **C**). Also at minimum, the number of PSUs must be not less than the number of SBMs plus 1. If 6 or more SBMs are installed then all PSUs should therefore be switched on.

Figure 6.1. Turning on power

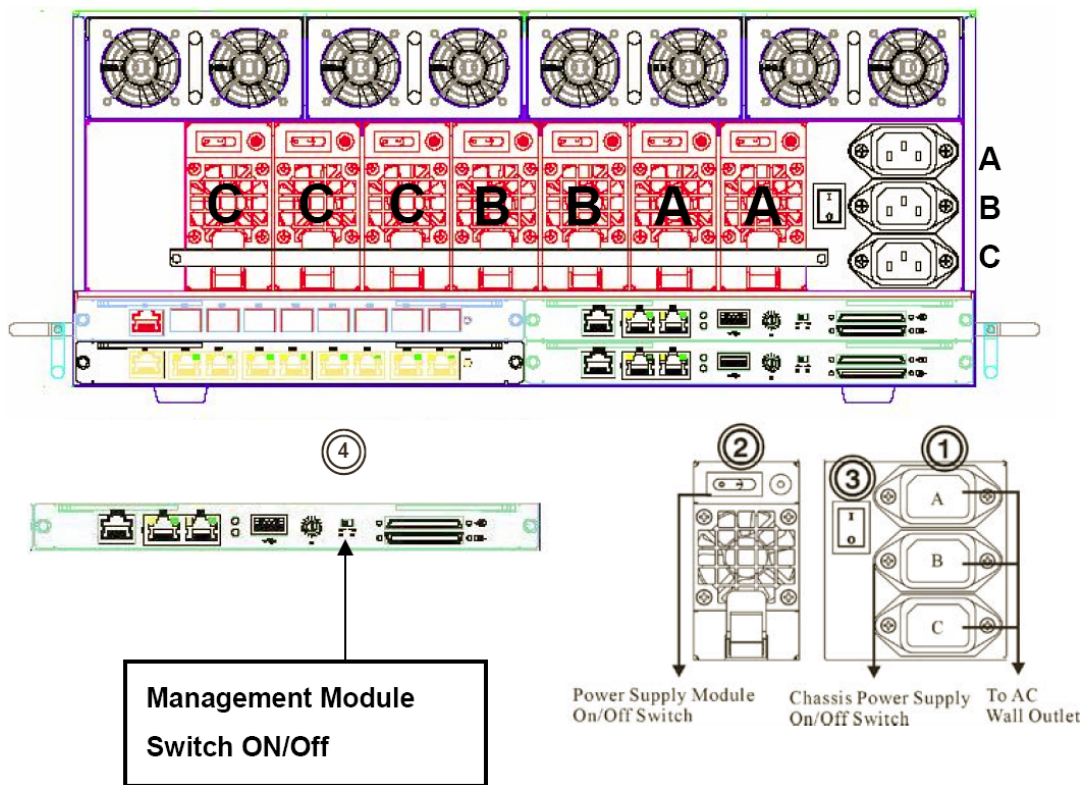

The following steps should be followed to power on the chassis:

1. Ensure the Secure Blade Modules are in place in the chassis. It is recommended that at least 1 Secure Blade Module has been fitted into the chassis before power on.
2. Use the 3 AC power cords to connect the SG5500 Series chassis to the power source from AC wall sockets. If possible use 3 power outlets connected to independent supply circuits with separate circuit breakers.
3. Press the ON/OFF switch (labelled **2** above) on each PSU to turn on the power supplies. This will put the PSUs in standby mode.

4. Set the Chassis Management Module power supply On/Off switch to its "On" position (labelled **4** above) to turn on power to the whole chassis. *It is NOT necessary to use the main chassis power switch located to the left of the power inlets (labelled **3** above) since the CMM can control the whole power up process..*
5. The whole chassis will now power on under the control of the CMM. First the PSUs will switch to their active state and the CFT fans will start. After several seconds the SBMs will power on, one after the other, in a sequential order going from left to right.

After a power-loss scenario it is not necessary to power on the chassis manually as this will be done automatically.



Warning

Always wait at least 5 seconds after turning off the system before turning it back on; turning power on and off in rapid succession can damage electrical circuitry.

A recommended method of connecting power to the SG5500 Series device is via an Uninterruptible Power Supply (UPS).

Figure 6.2. A UPS unit

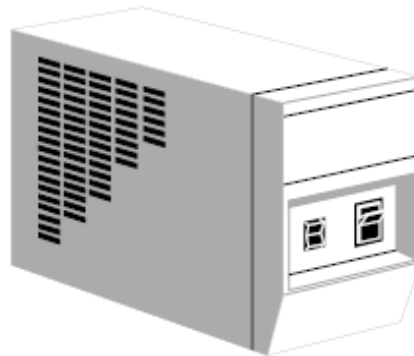

If a UPS unit is unavailable then a power strip with a built in surge protector is recommended. Do not use inferior extension cords as this can result in damage to your system.

Figure 6.3. A power strip

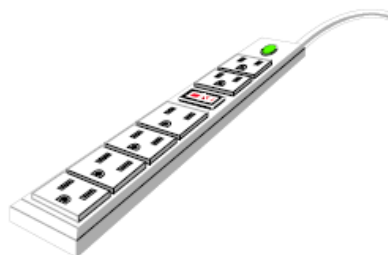

Powering Off

Powering off can be done through the CMM interfaces or manually by pressing the black chassis power supply switch (labelled **3**) in for at least 5 seconds. This switch is a rocker switch on a spring and will spring back to its "Off" position when released. The CMM will remain powered on and in standby mode with its power LED illuminated, however the heat generated by the CMM doesn't require fan cooling.

Chapter 7. CorePlus Console Setup

- Configuring CorePlus, page 32
- Finalizing the Configuration, page 34

7.1. Configuring CorePlus

Each SBM in the SG5500 Series chassis must have the CorePlus operating system separately configured. First make sure the SG5500 Series is powered up and all SBMs are also powered up. Make sure that a terminal (or a computer running terminal emulation software) is connected to the RS232 console port on the Chassis Management Module. (A console could be connected to each SBM in turn, via the Micro D-Sub I/O port on the front of each SBM but this is not recommended). For each SBM:

1. Press the "KVM Access" switch on the SBM to configure the blade to be the one accessed by the console port.
2. Assuming that the console is connected and terminal software is active, press the **ESC** key to refresh the terminal screen.
3. A text similar to the following will appear in the terminal window:

```
=====
  Select Management Interface
=====
This will setup a small base configuration needed for the
system to start, and for remote management of the
Security Gateway to work. When this procedure is finished,
the remaining parts of the configuration may be completed
remotely using the Security Gateway Manager software.

Please choose your management interface
-----
cmm: Fast Ethernet interface 10/100
ge1: Gigabit Ethernet interface 1000BaseT
ge2: Gigabit Ethernet interface 1000BaseT
-----
ESC Return to previous menu
```

4. Select the interface that you have chosen for communication with the management station running the FineTune software. Press *Enter* to confirm your choice.
5. Enter the IP address you intend to use for the Clavister FineTune management interface and enter the appropriate netmask and default gateway. Each SBM must have a different address as they will be managed as separate entities. It is also possible to specify a remote management network if it is different from the local management interface sub-net. Press **Ctrl-S** to save the settings and continue.

The *Default Gateway* does not need to be specified if the management workstation is local. If, however, the management workstation is at least one router hop away from the appliance then the *Default Gateway* needs to be specified so that the appropriate entry is placed in the CorePlus routing table which is otherwise empty. Specifying the *Remote Mangement Net* is also required if the management workstation is not local.

```

=====
Base IP configuration
=====
Management Interface:
cmm: Fast Ethernet interface 10/100

Use DHCP:          [ ]
Use PPPoE:         [ ]

IP Address:        [192.168.10 .10 ]
Netmask:           [255.255.255.0# ]
Gateway Address:   [ . . . ] (Leave blank for none)
Allowed Mgmt Net: [ . . . ] (Leave blank for local
network)
Netmask:           [ . . . ]

NOTE: If this interface is NOT the external interface,
the gateway address should normally be left blank.
-----

```

**Note**

It is possible to use DHCP on the interface.

6. The following will appear in the terminal window:

```

=====
Generating Base Configuration
=====
Writing configuration file, please wait...Done.
It is recommended to start the core now.

```

Press **Y** to start CorePlus.

7. You will receive a confirmation message that CorePlus has successfully started as shown below:

```
Configuration done
```

7.2. Finalizing the Configuration

After the initial SBM setup, the user should refer to the companion publications found in PDF format on the accompanying CD for information on how to begin to further configure and manage the SBM:

**Clavister FineTune
Administrators Guide**

Clavister FineTune is a software tool that provides the principal management interface for the CorePlus operating system. FineTune runs on a Windows based PC workstation and is used by the administrator to manage the operation of the CorePlus software running in each SG5500 Series SBM.

Each SBM is treated as a distinct, autonomous Clavister Security Gateway in a FineTune software configuration. This manual describes how to register your Clavister license, how to define each Clavister Security Gateway to be managed and an introduction on configuring security policies.

**Clavister CorePlus
Administrators Guide**

This describes the general operation and control of the CorePlus firmware, which is the Clavister proprietary operating system that drives and controls the Clavister SG5500 Series SBMs. The document includes examples of how to carry out typical administrative tasks such as setting up a VPN, and how to use the SG5500 Series in various scenarios including UMA/GAN configurations.

Clavister Log Reference Guide

This documents and describes all log messages that might be generated by CorePlus during operation of the system.



Tip

These publications can also be downloaded from <http://www.clavister.com>.

Chapter 8. The CMM Web-Interface

- Chassis Remote Management, page 36
- The Health Monitor, page 37
- Hardware Control, page 40
- Version Information, page 43
- System Administration, page 45
- Account Management, page 50

8.1. Chassis Remote Management

The SG5500 Series Chassis Management Module offers a Web-Interface to access management functions. This interface can be accessed using a standard web-browser connected via Ethernet to the LAN1 or LAN2 ports of the Chassis Management Module.

To access the Web-Interface remotely, browse to the login page at the configured IP address. If the IP address has not been changed then browse to the default address which is *192.168.1.100*. An initial login screen will be displayed as shown below.

Figure 8.1. CMM Web-Interface login

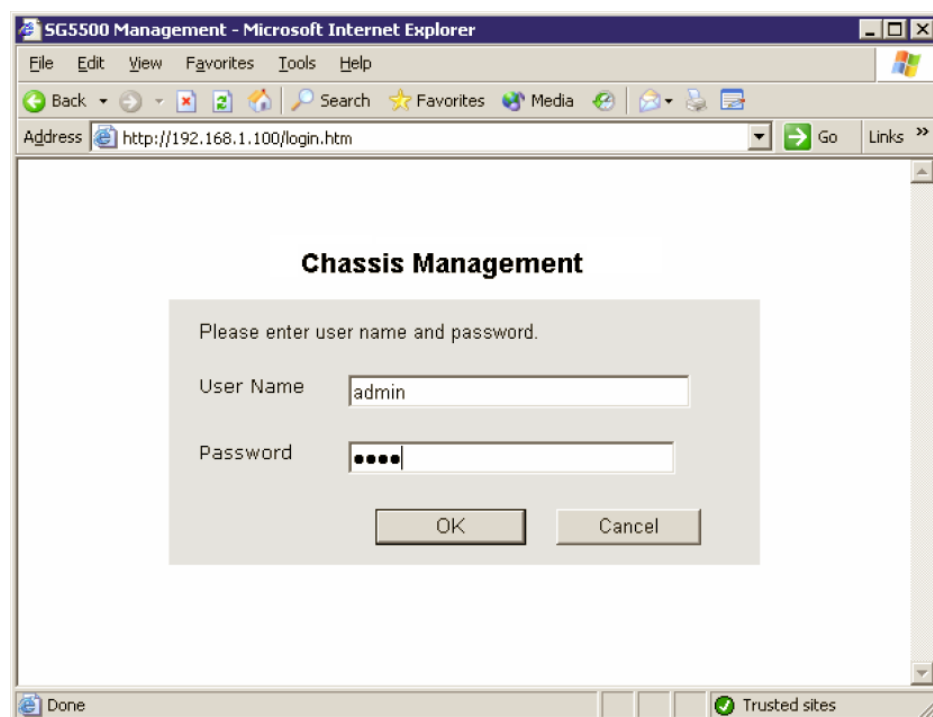

The initial default username is *admin* and the default password is *1234*. Both username and password are case sensitive. (Neither is sent to the CMM as unencrypted text).



Important

The browser used must have Javascript enabled for the login process to function correctly.

8.2. The Health Monitor

Chassis Status

A screen shot of the first webpage shown after login, the Chassis Status page, is shown below. This is part of the Health Monitor.

Figure 8.2. Chassis Status

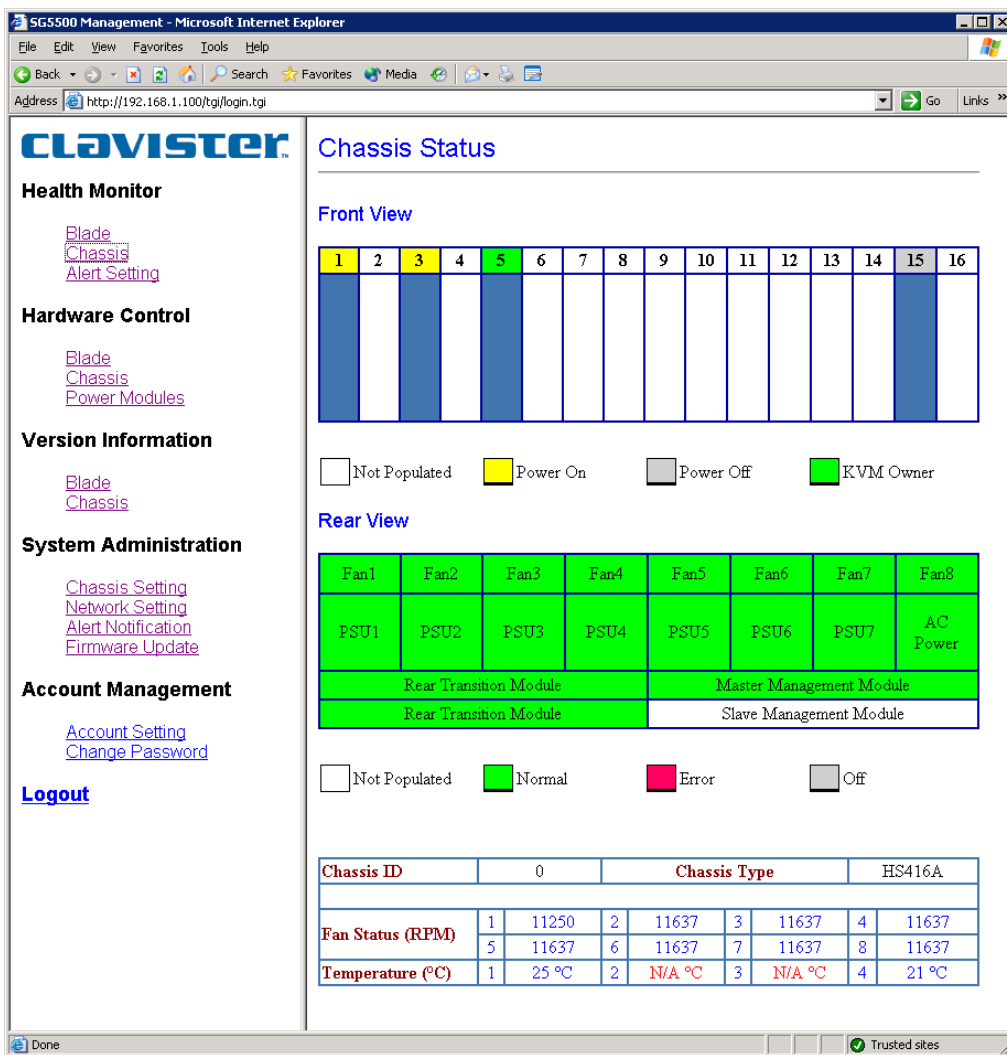

The main sections of the Chassis Status webpage are:

Front view

Displays the populated slots. The SG5500 Series SBM is a dual slot blade and therefore will only occupy odd numbered slots 1, 3, 5, 7, 9, 11, 13 and 15. The indicator colors for power On, Off, selected KVM and unpopulated slots are: Red indicates an error condition; Blue indicates normal operation.

Fan status

Chassis fan speeds are shown measured in RPM. Red indicates an error; Blue indicates normal operation.

Temperature status

Temperature readings come from the chassis temperature sensors. Red

indicates abnormal temperature; Blue indicates normal temperature. There are 2 sensors located in a chassis. Sensor **S1** is located at the back of the electronics assembly closest to the fans. The second sensor **S4** measures temperatures at the side of the electronics assembly nearest the front of the SG5500 Series. "N/A" indicates that no sensor is attached.

Rear View

Indicates active or inactive chassis PSUs, RTMs and CFTs. Red indicates failure; green indicates normal operation; gray indicates Off; white indicates an absent module.

The left hand menu bar contains a list of options to display and control other aspects of SG5500 Series operation. These are discussed in the following sections.

Blade Status

The status of all SBMs is shown on the Blade Status webpage and is color coded in the same way as the Chassis Status page. As mentioned earlier, the SBM is a dual slot blade which can only occupy odd slots.

Figure 8.3. SBM Status webpage

Blade ID	Fan	Temperature	Vcore
Blade 1	28125 rpm	33 °C	1.10 V
Blade 2	-- rpm	-- °C	-- V
Blade 3	8437 rpm	48 °C	1.32 V
Blade 4	-- rpm	-- °C	-- V
Blade 5	28125 rpm	34 °C	1.08 V
Blade 6	-- rpm	-- °C	-- V
Blade 7	-- rpm	-- °C	-- V
Blade 8	-- rpm	-- °C	-- V
Blade 9	-- rpm	-- °C	-- V
Blade 10	-- rpm	-- °C	-- V
Blade 11	-- rpm	-- °C	-- V
Blade 12	-- rpm	-- °C	-- V
Blade 13	-- rpm	-- °C	-- V
Blade 14	-- rpm	-- °C	-- V
Blade 15	28125 rpm	29 °C	1.12 V
Blade 16	-- rpm	-- °C	-- V

Figure 8.4. SBM Status color indicators

White	Unpopulated
Yellow	Powered on
Green	Powered on and KVM active
Red	Indicates threshold limit

Alert Settings

Various e-mail alerts can be triggered by enabling the checkboxes on the Alert Settings webpage. Alert thresholds for fan speed and temperature limits can be changed by using the "+" or "-" buttons.

Figure 8.5. Alert Settings page

Alert Setting	
Health Monitor Alert	
<input type="checkbox"/> Chassis Fan	<input type="checkbox"/> Blade Fan
<input type="checkbox"/> Chassis Thermal	<input type="checkbox"/> Blade Temperature
<input type="checkbox"/> Chassis Voltage	<input type="checkbox"/> Blade Vcore
Power Module Monitor Alert	
<input type="checkbox"/> Power Module 1	<input type="checkbox"/> Power Module 2
<input type="checkbox"/> Power Module 3	<input type="checkbox"/> Power Module 4
<input type="checkbox"/> Power Module 5	<input type="checkbox"/> Power Module 6
<input type="checkbox"/> Power Module 7	
<input type="button" value="Submit"/>	
Chassis Fan Threshold	
Upper Critical (RPM)	- <input type="text" value="56250"/> +
Upper Warning (RPM)	- <input type="text" value="13500"/> +
Lower Warning (RPM)	- <input type="text" value="8881"/> +
Lower Critical (RPM)	- <input type="text" value="8035"/> +
Chassis Temperature Threshold	
Critical (°C)	- <input type="text" value="50"/> +
Warning (°C)	- <input type="text" value="35"/> +
<input type="button" value="Load Default"/>	<input type="button" value="Submit"/>

Go to the **Alert Notification** webpage in the **System Administration** section of the Web-Interface to change the alert target e-mail address.

8.3. Hardware Control

Blade

Each SBM slot is represented by a blade ID reference (as mentioned earlier, SBMs only occupy odd slots). Blades can be powered Off, On or be reset by clicking the Power Control radio-buttons followed by clicking the **Submit** button.

The same status coloring scheme used for the chassis summary webpage is used for the status of each blade.

Figure 8.6. SBM Control page

Blade Control

Chassis ID

KVM ON

Blade ID	Power Control	Boot Device	Status
Blade 1	<input checked="" type="radio"/> On <input type="radio"/> Off <input type="radio"/> Reset	BIOS Default <input type="button" value="v"/>	Power On
Blade 2	<input type="radio"/> On <input checked="" type="radio"/> Off <input type="radio"/> Reset	Select Boot Device <input type="button" value="v"/>	---
Blade 3	<input checked="" type="radio"/> On <input type="radio"/> Off <input type="radio"/> Reset	BIOS Default <input type="button" value="v"/>	KVM On
Blade 4	<input type="radio"/> On <input checked="" type="radio"/> Off <input type="radio"/> Reset	Select Boot Device <input type="button" value="v"/>	---
Blade 5	<input checked="" type="radio"/> On <input type="radio"/> Off <input type="radio"/> Reset	BIOS Default <input type="button" value="v"/>	Power On
Blade 6	<input type="radio"/> On <input checked="" type="radio"/> Off <input type="radio"/> Reset	Select Boot Device <input type="button" value="v"/>	---
Blade 7	<input type="radio"/> On <input checked="" type="radio"/> Off <input type="radio"/> Reset	Select Boot Device <input type="button" value="v"/>	---
Blade 8	<input type="radio"/> On <input checked="" type="radio"/> Off <input type="radio"/> Reset	Select Boot Device <input type="button" value="v"/>	---
Blade 9	<input type="radio"/> On <input checked="" type="radio"/> Off <input type="radio"/> Reset	Select Boot Device <input type="button" value="v"/>	---
Blade 10	<input type="radio"/> On <input checked="" type="radio"/> Off <input type="radio"/> Reset	Select Boot Device <input type="button" value="v"/>	---
Blade 11	<input type="radio"/> On <input checked="" type="radio"/> Off <input type="radio"/> Reset	Select Boot Device <input type="button" value="v"/>	---
Blade 12	<input type="radio"/> On <input checked="" type="radio"/> Off <input type="radio"/> Reset	Select Boot Device <input type="button" value="v"/>	---
Blade 13	<input type="radio"/> On <input checked="" type="radio"/> Off <input type="radio"/> Reset	Select Boot Device <input type="button" value="v"/>	---
Blade 14	<input type="radio"/> On <input checked="" type="radio"/> Off <input type="radio"/> Reset	Select Boot Device <input type="button" value="v"/>	---
Blade 15	<input checked="" type="radio"/> On <input type="radio"/> Off <input type="radio"/> Reset	BIOS Default <input type="button" value="v"/>	Power On
Blade 16	<input type="radio"/> On <input checked="" type="radio"/> Off <input type="radio"/> Reset	Select Boot Device <input type="button" value="v"/>	---

If using the RS-232 serial console on the CMM for KVM or console access to an SBM, then a particular SBM can be made the "active" connected to the console port by using the combo-box labeled **KVM ON** at the top of the webpage to select an SBM which is powered on.



Caution

Changing the **Boot Device** option is not recommended. The default value for this setting is *BIOS Default*. Contact product support for more information about this option.

Chassis

This page can controls Power to the entire chassis and offers the ability to reset a Chassis Management Module individually. To power down the entire chassis and all active blades, select the **Off** radio-button and press **Submit**.



Note

This will not turn off power to the CMM which will remain in standby mode.

Figure 8.7. Chassis Control page

Chassis Control

Chassis ID	0	Chassis Type	HS416A
Power Control	<input checked="" type="radio"/> On <input type="radio"/> Off	<input type="button" value="Submit"/>	
Reset CMM	All management users will be disconnected. <input type="checkbox"/> Verify Reset.		<input type="button" value="Reset CMM"/>

If a reset of a CMM is necessary, mark the **Verify Reset** checkbox and click the **Reset CMM** button.

Power Modules

This display can be used to turn individual PSUs On or OFF by selecting the appropriate power control radio button for a particular PSU and then clicking the **Action** button. It also shows PSU temperatures as well as status of the cooling fans that are integrated into each PSU.

Figure 8.8. PSU Control

Power Status

Module ID	Power Control	Fan Status	Temperature	Module Status
Module 1	<input checked="" type="radio"/> On <input type="radio"/> Off	OK	24 °C	Power OK
Module 2	<input checked="" type="radio"/> On <input type="radio"/> Off	OK	26 °C	Power OK
Module 3	<input checked="" type="radio"/> On <input type="radio"/> Off	OK	25 °C	Power OK
Module 4	<input checked="" type="radio"/> On <input type="radio"/> Off	OK	26 °C	Power OK
Module 5	<input checked="" type="radio"/> On <input type="radio"/> Off	OK	27 °C	Power OK
Module 6	<input checked="" type="radio"/> On <input type="radio"/> Off	OK	27 °C	Power OK
Module 7	<input checked="" type="radio"/> On <input type="radio"/> Off	OK	26 °C	Power OK

**Note**

If the chassis Auto Power-on function is enabled, powering off a PSU will only result in a short period in the power-off state. This will be the case if the power off is done through the Power Status web page above or through the Chassis Control web page.

To make sure a PSU doesn't power-on automatically, first disable the chassis auto-power function in the "Chassis Setting" web page (see Section 8.5, "System Administration").

8.4. Version Information

Blade

Two sections summarize SBM version information. The top box contains all available information based on the selected slot ID. The bottom box shows selected information on all available slots.

Figure 8.9. SBM Version information

Blade Version Information

Slot ID	1
Blade Type	HDB42742
Serial Number	55007357-1000001
Hardware Version	50BA
Firmware Version	E01
BIOS Version	GE1.0
CPU	Intel 2.8 GHz
Memory	4096 MB
Mac Address (Gb1)	00:00:10:10:00:FA
Mac Address (Gb2)	00:00:10:10:00:FB
Mac Address (10/100)	00:00:10:10:00:FC

Slot ID	Blade Type
1	HDB42742
2	Not Populated
3	HDB42742
4	Not Populated
5	HDB42742
6	Not Populated
7	Not Populated
8	Not Populated
9	Not Populated
10	Not Populated
11	Not Populated
12	Not Populated
13	Not Populated
14	Not Populated
15	HDB42742
16	Not Populated



Note

If an upgrade of the SG5500 Series SBM BIOS or Control Processor Firmware is required ("Firmware Version" in the above image), please refer to the documentation accompanying the upgrade package. Details of the upgrade procedure are not included in this manual since they can differ from upgrade to upgrade. When released, upgrade packages are supplied through SG5500 Series customer support.

Chassis

The Chassis Version page contains details of the chassis.

Figure 8.10. Chassis Version information

Chassis Version Information

Chassis Type	HS416A
Chassis Serial Number	550073570-100001
CMM Type	AMB416A
CMM Firmware Version	Version 1.3.03
CMM Serial Number	550073571-101001
CMM Mac Address	00:00:10:01:10:FE

For information about any firmware upgrades, please contact SG5500 Series customer support.

8.5. System Administration

Chassis Settings

Figure 8.11. Chassis Settings Information

Chassis Setting

Chassis ID	Rack ID	Slot ID
0	-- ▾	-- ▾
Auto Power On	<input checked="" type="checkbox"/> Chassis <input checked="" type="checkbox"/> Blades	
Nexcare Protocol	<input type="radio"/> Enable <input checked="" type="radio"/> Disable	
SNMP Protocol	<input checked="" type="radio"/> Enable <input type="radio"/> Disable	
SNMP Community	<input type="text" value="public"/>	

ID	Rack ID	Slot ID	IP Address
0	1	1	192.168.1.100
1	--	--	--
2	--	--	--
3	--	--	--
4	--	--	--
5	--	--	--
6	--	--	--
7	--	--	--
8	--	--	--
9	--	--	--
10	--	--	--
11	--	--	--
12	--	--	--
13	--	--	--
14	--	--	--
15	--	--	--

The Chassis settings consist of:

- | | |
|-------------------------|--|
| Chassis ID | Displays the setting selected by the ID dial located on the CMM |
| Rack ID/Slot ID | Used to set the detailed rack and slot location at the installation site |
| Auto Power On | Enables or disables the automatic startup of chassis and blades after complete power-loss. <ul style="list-style-type: none"> Chassis power supplies startup within 30 seconds SBMs startup after a further 30 seconds |
| Nexcare Protocol | An unsupported chassis protocol. This should NOT be enabled |
| SNMP | <ul style="list-style-type: none"> SNMP - Enables/Disables CMM SNMP support. Disabled is the default. |

- **SNMP Community** - Sets the SNMP write community string

SNMP control and SNMP Traps

The above SNMP option enables SNMP control. This allows querying by an external workstation running an SNMP client. This workstation can then be used to such features as SNMP trap generation as a compliment to email alert generation. Further SNMP documentation can be found in Appendix A, *SNMP Examples*.

Network Settings

Changing the SG5500 Series Chassis Management Module IP address from the current or default IP is done by entering new IP information into the respective input fields and pressing the **Submit** button.

Figure 8.12. Network Settings

Network Setting	
IP Address:	192 . 168 . 1 . 100
Subnet Mask:	255 . 255 . 255 . 0
Default Gateway:	192 . 168 . 1 . 254
DHCP Client	<input type="radio"/> Enable <input checked="" type="radio"/> Disable
<input type="button" value="Submit"/> <input type="button" value="Cancel"/>	

It is also possible to enable or disable support for a DHCP assigned IP address.

Alert Notification

This webpage sets the system contact e-mail address and mail-server. When the Chassis Management Module detects a problem or potential problem, an alert-mail will be sent to the contact e-mail address specified.

Figure 8.13. Alert Notification

Alert Notification	
Send To:	<input type="text"/>
Mail Server:	<input type="text"/>
Warning Subject:	<input type="text"/>
<input type="button" value="Submit"/> <input type="button" value="Send"/> <input type="button" value="Cancel"/>	

Upgrading Firmware

When upgrading the SG5500 Series Chassis Management Module firmware, the CMM is put into Firmware Update Mode and normal operation of the CMM will be interrupted. Follow the following steps to upgrade:

1. To begin the upgrade procedure, press the **Update** button.

Figure 8.14. Firmware Update

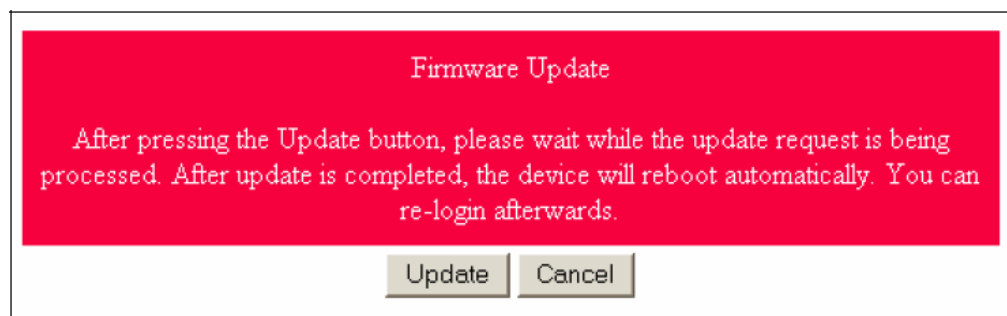

Important

After starting the firmware upgrade procedure, the upgrade must be completed before the CMM can be restored to normal operation.

2. A waiting dialog will now appear which will show a count-down while the system prepares for the upgrade. This should take about 6 seconds. The **Continue** button in the dialog should then be pressed.
3. Open a file chooser dialog by clicking the **Browse** button.

Figure 8.15. Select firmware file

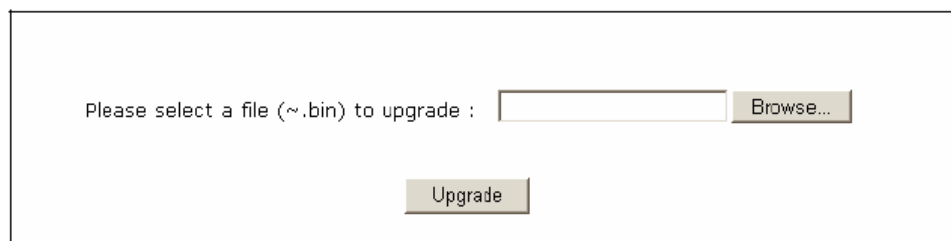

4. Select the binary firmware upgrade file with the file chooser dialog and click **Open**.

Figure 8.16. Select binary firmware file

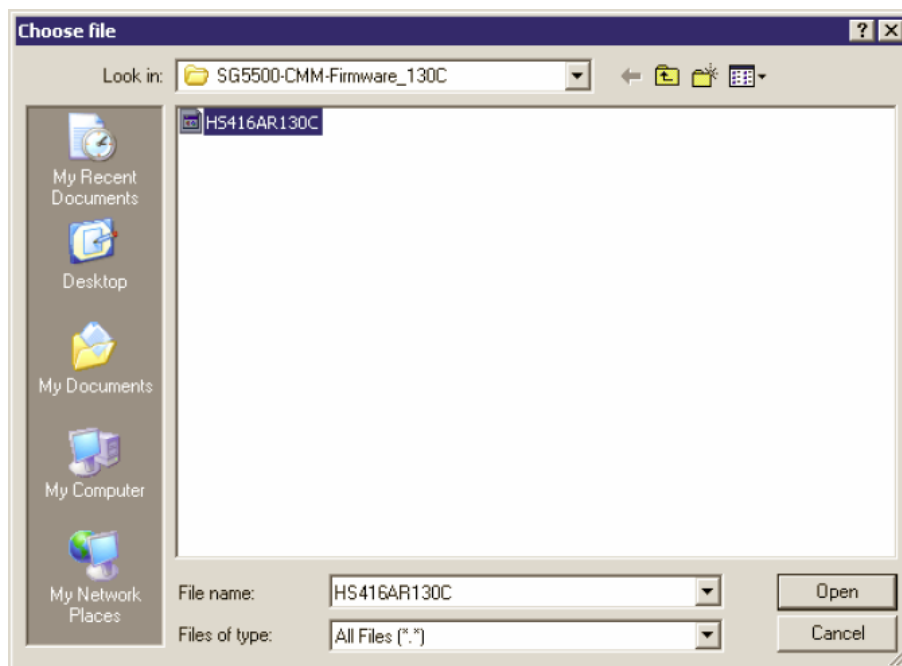

- Next, click the **Upgrade** button to start the process of upgrading the firmware.

Figure 8.17. Start firmware upgrade

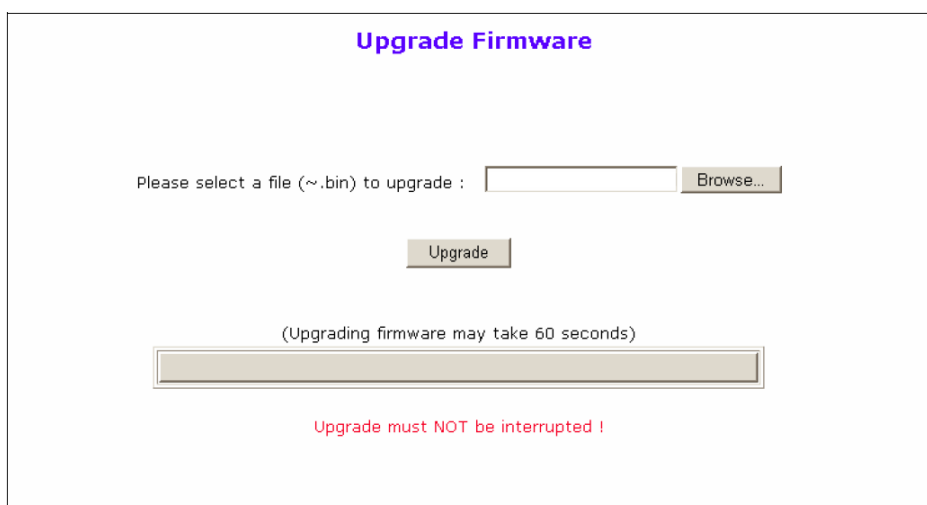

- The upgrade process takes up to 60 seconds to complete. The progress bar will show the current status while the upgrade is running.

Figure 8.18. Upgrade firmware progress bar

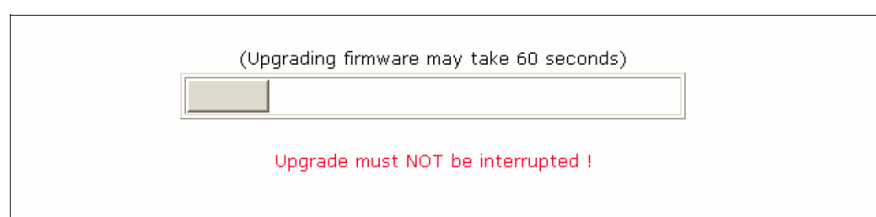

**Warning**

Do not turn off power to the chassis or CMM during this time so as to avoid damage to the CMM firmware code.

7. A waiting dialog will now appear while the system prepares for re-login. This will take about 6 seconds. Wait until the **Re Login** button is enabled, then click it to reconnect to the CMM login page.

The upgrade process is now finished. The current firmware version can be checked in the **Version Information** section of the Chassis Management Module interface.

8.6. Account Management

Account Settings

Figure 8.19. Account Management page

	Account	Status	Edit		Account	Status	Edit
<input type="checkbox"/>	guest	active	Edit	<input type="checkbox"/>	---	---	Edit
<input type="checkbox"/>	---	---	Edit	<input type="checkbox"/>	---	---	Edit
<input type="checkbox"/>	---	---	Edit	<input type="checkbox"/>	---	---	Edit
<input type="checkbox"/>	---	---	Edit	<input type="checkbox"/>	---	---	Edit
<input type="checkbox"/>	---	---	Edit	<input type="checkbox"/>	---	---	Edit
<input type="checkbox"/>	---	---	Edit	<input type="checkbox"/>	---	---	Edit
<input type="checkbox"/>	---	---	Edit	<input type="checkbox"/>	---	---	Edit
<input type="checkbox"/>	---	---	Edit	<input type="checkbox"/>	---	---	Edit
<input type="checkbox"/>	---	---	Edit	<input type="checkbox"/>	---	---	Edit
<input type="checkbox"/>	---	---	Edit	<input type="checkbox"/>	---	---	Edit
<input type="checkbox"/>	---	---	Edit	<input type="checkbox"/>	---	---	Edit
<input type="checkbox"/>	---	---	Edit	<input type="checkbox"/>	---	---	Edit
<input type="checkbox"/>	---	---	Edit	<input type="checkbox"/>	---	---	Edit
<input type="checkbox"/> Total: 1 accounts. (1 active, 0 inactive.)							
				<input type="button" value="Active"/> <input type="button" value="Inactive"/> <input type="button" value="Add"/> <input type="button" value="Delete"/>			

The Account Management section is used to add more users to the CMM Web-Interface. A users can be permitted access to only one of the blades if that is required.

To add a new user, click the **Add** button on the lower left side of the webpage. To inactivate an account select the account using the checkbox to the right of the username and press the **Inactive** button. To reactivate the user, click the same checkbox and then the **Active** button. The **Edit** button is used to change an existing user account. Use the **Delete** button to remove an entire user account.

 **Note**
The "admin" user cannot be removed.

Add/Edit a Web-Interface Account

To add or change user information click the **Add** or **Edit** button on the Account Management webpage. Enter the new details, select the SBM the user will have administrative rights for and press **Submit** to save.



Note

By unchecking all checkboxes in the Blade Control Permission section, a user can be created who can monitor the chassis and its components but cannot alter settings. This user type is known as an "audit" user.

Figure 8.20. Defining a Web-Interface account

User Name	<input type="text" value="guest"/>
Password	<input type="text" value="guest"/>
Active	<input checked="" type="radio"/> active <input type="radio"/> inactive
Blade Control Permission	<input checked="" type="checkbox"/> 1 <input type="checkbox"/> 2 <input checked="" type="checkbox"/> 3 <input type="checkbox"/> 4 <input type="checkbox"/> 5 <input type="checkbox"/> 6 <input type="checkbox"/> 7 <input type="checkbox"/> 8 <input type="checkbox"/> 9 <input type="checkbox"/> 10 <input type="checkbox"/> 11 <input type="checkbox"/> 12 <input type="checkbox"/> 13 <input type="checkbox"/> 14 <input type="checkbox"/> 15 <input type="checkbox"/> 16
<input type="button" value="Submit"/> <input type="button" value="Reset"/> <input type="button" value="Cancel"/>	

Change an Account Password

Use this webpage to change the password used for access to the Web-Interface. Type in the old password, then new password and retype the new password. Then click the **Submit** button.

Figure 8.21. Changing an Account Password

Change Password

Account:	admin
Old Password:	<input type="text"/>
New Password:	<input type="text"/>
Confirm New Password:	<input type="text"/>

The password has now been changed for the active account.

Chapter 9. Hot-Swapping Components

- Hot-Swapping Secure Blade Modules, page 53
- Hot-Swapping PSUs, page 55
- CMM and RTM Hot-Swapping, page 57
- CFT Hot-Swapping, page 58

This chapter guides you through the process of hot swapping the SG5500 Series Secure Blade Modules, PSUs, Chassis Management Modules, Rear Transition Modules and Cooling Fan Trays.

9.1. Hot-Swapping Secure Blade Modules

In order to hot-swap an SBM:

1. Power off the SBM either by using the Web-Interface or by physically pressing the blade's power button and holding it in for 5 seconds.



Warning

Wait at least five seconds after turning off the power before removing the SBM from the chassis.

Figure 9.1. SBM Hot-Swapping

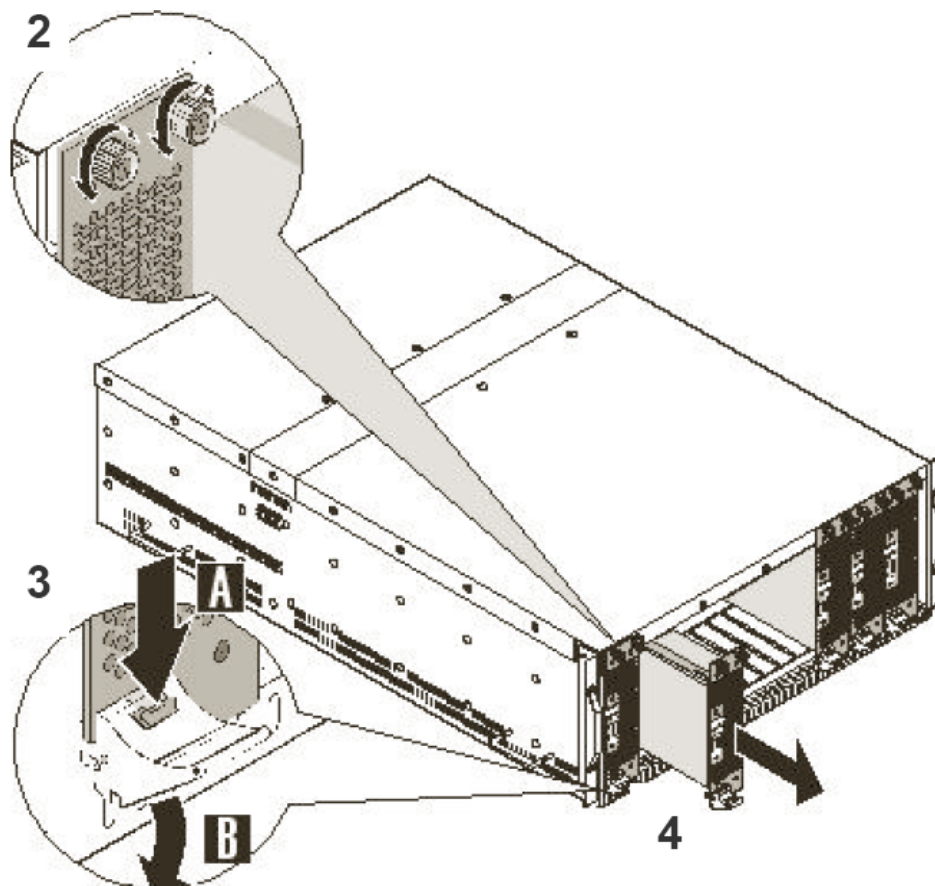

2. Loosen the two top screws and the single screw at the base that fasten the SBM tray to the chassis. Do not remove the screws completely.
3. Release the lever at the base of the blade using a thumb grip, pressing both the red release safety (A) and pressing down (B), causing the blade to eject from the slot.
4. Slide the blade out of the chassis slot.
5. Slide the new SBM into the chassis holding the release lever (B) down until the blade is locked into its connector again. Then gently pull the lever upwards again with one hand and press with the other hand on the top of the blade to make the red safety button snap into the locked position again.
6. Tighten the three screws on the front panel to safely hold the SBM in place.
7. Now press the power button on the SBM and hold it in for 5 seconds to power it up. When an SBM is first inserted into a live chassis, power must be manually switched on.

Pre-loading CorePlus on a standby SBM

It is possible to pre-load a standby SBM with a licensed and fully functioning copy of CorePlus ready for use as a replacement unit. A single CorePlus license allows two changes of MAC address. It is therefore possible to generate a new license for a spare SBM, pre-load it, and as long as the original and standby SBM are not in use at the same time then this is within the terms of the license agreement.

9.2. Hot-Swapping PSUs

The Clavister SG5500 Series chassis contains seven (7) Power Supply Units (PSUs). These are secured to the chassis by a locking handle and a locking strip located on the bottom of the module.

Figure 9.2. A Power Supply Unit (PSU)



Figure 9.3. PSU Hot-Swapping

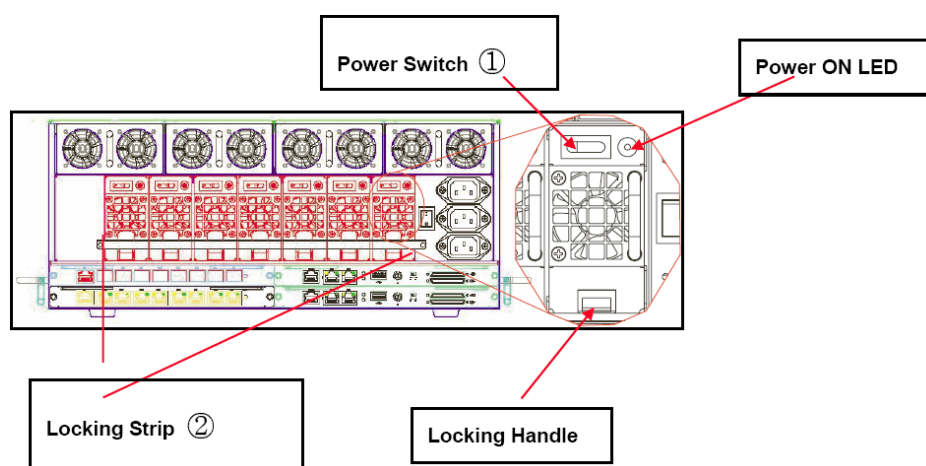

Note

When the PSU is turned on, and the condition of the module is normal, the PSU status LED illuminates green. A red LED indicates the power supply has failed. The light is off when the power module is turned off.

To Hot-Swap a PSU:

1. Turn off the PSU power switch (1).
2. Unscrew the locking screws on both sides to take off the locking strip (2).
3. Push the lower handle upwards on the module.

4. Pull the PSU by the handle and remove it.
5. Turn off the new PSU's power switch before inserting the module.
6. Push the new PSU into the chassis.
7. Fasten the securing metal bar across all PSUs with the 2 securing screws at either side.
8. Turn on the power switch on the new PSU. The PSU will now be in active mode.
9. Press the chassis power supply On/Off switch, holding it only briefly. This will send a pulse to the PSU instructing it to move from standby to active mode.

**Caution**

If the chassis power supply On/Off switch is held in for more than 4 seconds, the entire SG5500 Series chassis will be switched off.

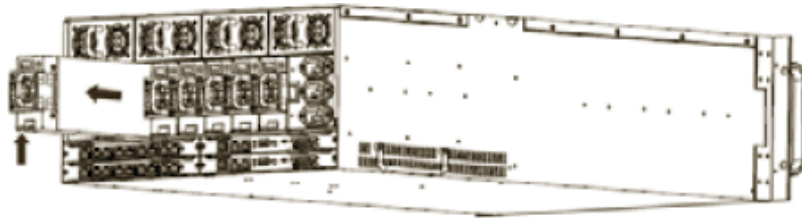
Figure 9.4. Removing a PSU

9.3. CMM and RTM Hot-Swapping

To hot-swap a Chassis Management Module or Rear Transition Module:

1. Power off the CMM or RTM
2. Remove the 2 securing screws at either side
3. Hold the two locking levers and pull them toward you to take out the blade

To replace the blade:

1. Align the CMM or RTM with the desired slot and insert the module into the slot until it is almost level with the chassis casing and only a small distance remains until its final position.
2. Push the two locking levers inwards to move the module further and lock it into its correct position. It is not necessary to push it all the way in before securing it with the locking levers. **DO NOT** force the module as this can damage it.

Figure 9.5. Blade locking levers

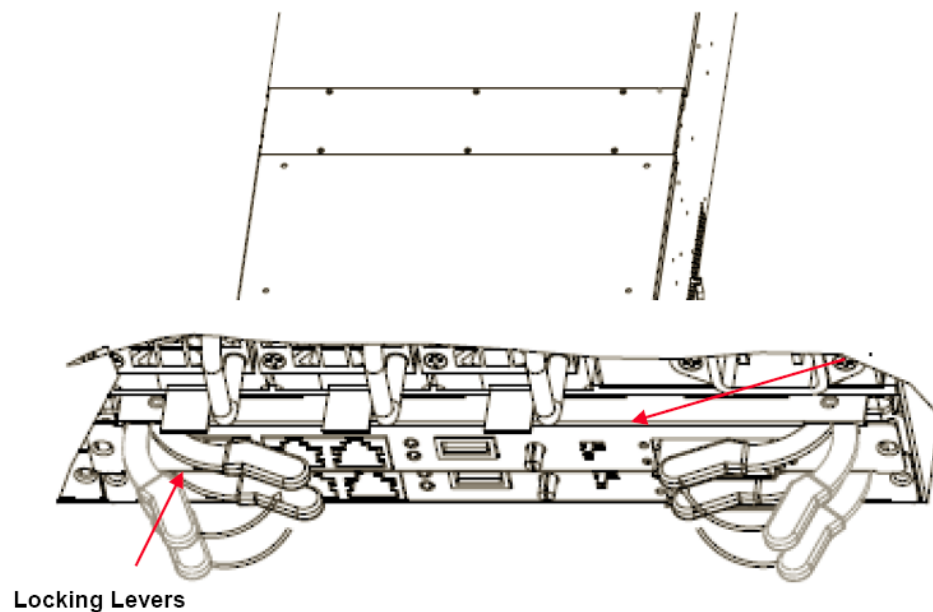

9.4. CFT Hot-Swapping

The Cooling Fan Trays (CFTs) located on the back of the SG5500 Series chassis, which provide air-flow, can be hot-swapped. There are 4 CFT units, each containing two fans. No-matter how many Secure Blade Modules are fitted, all 4 CFTs should be in place and running to provide maximum air-flow.

Figure 9.6. A Cooling Fan Tray (CFT)



Should a single fan fail in a CFT then the SG5500 Series is able to continue to function for an extended period with that single failure. However the CFT containing the failed fan should be replaced as soon as possible. It is not possible to replace a single fan within a CFT so the whole CFT must be replaced.

To replace a CFT:

1. Release the CFT from the chassis by pulling the handle firmly outwards
2. Push the replacement CFT unit back into place with the fan connector facing downwards
3. The replacement unit will startup automatically

Figure 9.7. Cooling Fan Tray Hot-Swapping

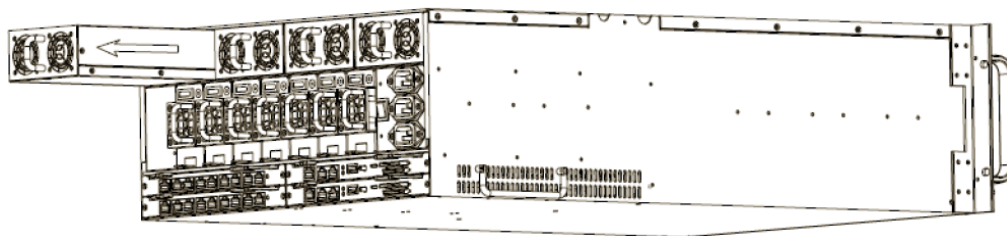

Note

The SG5500 Series fans are liable to wear from mechanical movement. Although the fans are built for prolonged use it is nonetheless a recommended precaution that the SG5500 Series CFT modules be replaced every two years.

Chapter 10. Safety Advisory

- Safety Information, page 60
- Wichtige Information zur Sicherheit Sicherheitshinweise, page 62

10.1. Safety Information

1. Read these safety instructions carefully.
2. Keep this Manual for later reference.
3. Disconnect this equipment from power outlets before cleaning. Don't use liquid or sprayed detergent for cleaning. Use a moist cloth for cleaning.
4. For plug-in equipment, the socket-outlet shall be installed near the equipment and shall be easily accessible.
5. Keep the equipment away from humidity.
6. Place the equipment on a stable surface when installed. If the equipment falls it could cause injury.
7. Do not leave the equipment in an uncontrolled environment, or a temperature above 50°C; it may damage the equipment.
8. The openings on the enclosure are for air convection and hence protects the equipment from overheating. **DO NOT COVER THE OPENINGS.**
9. Check the voltage of the power source when connecting the equipment to a power outlet.
10. Place the power cord in such a way that people cannot step on it. Do not place anything over the power cord. The power cord must be rated correctly for the product and for the voltage and current marked on the product's electrical ratings label. The voltage and current rating of the cord should be greater than the voltage and current rating marked on the product.
11. All cautions and warnings on the equipment should be noted.
12. If the equipment is not used for long periods, disconnect the equipment from the mains power to avoid it being damaged by transient voltage-spikes.
13. Never pour any liquid into ventilation openings; this could cause fire or electrical shock.
14. Never open the equipment. For safety reason, qualified service personnel only should open the equipment.
15. If one of the following situations arises, have the equipment checked by qualified service personnel:
 - i. The power cord or plug is damaged.
 - ii. Liquid has penetrated into the equipment.
 - iii. The equipment has been exposed to moisture.
 - iv. The equipment is not functioning correctly.
 - v. The equipment has been dropped or otherwise damaged.

- vi. If the equipment has obvious signs of breakage.
16. Do not place heavy loads on the equipment.
 17. Ensure that all KVM and Blade board screws are securely fastened. The unit uses a three-wire ground cable, which is equipped with a third pin to ground the unit to prevent electric shocks. Make sure that this pin is able to fulfill its purpose. If your outlet does not support this kind of plug, contact a suitably qualified electrician to replace your obsolete outlet. Do not hot-swap a Server Blade Module board when transferring configuration data or firmware updates.
 18. **CAUTION: THE EQUIPMENT IS FITTED WITH A BATTERY-POWERED REAL-TIME CLOCK CIRCUIT. THERE IS A DANGER OF EXPLOSION IF THE BATTERY IS INCORRECTLY REPLACED. REPLACE ONLY WITH THE SAME OR THE EQUIVALENT TYPE, AS RECOMMENDED BY THE MANUFACTURER. DISCARD USED BATTERIES ACCORDING TO THE MANUFACTURER'S INSTRUCTIONS.**

10.2. Wichtige Information zur Sicherheit Sicherheitshinweise

1. Bitte lesen Sie sorgfältig diese Sicherheitshinweise.
2. Bitte bewahren Sie dieses Benutzerhandbuch zur späteren Einsicht auf.
3. Bitte trennen Sie dieses Gerät vor seiner Reinigung von der Netzsteckdose. Benutzen Sie zur Reinigung kein flüssiges oder Spray-Reinigungsmittel. Benutzen Sie zur Reinigung ein feuchtes Tuch oder einen feuchten Lappen.
4. Bei steckbaren Geräten soll sich die Steckdose in der Nähe des Gerätes befinden und leicht zugänglich sein.
5. Bitte bewahren Sie dieses Gerät vor Feuchtigkeit.
6. Legen Sie dieses Gerät beim Einbau auf eine sichere Unterlage; Sturz oder Fall könnte es beschädigen.
7. Lassen Sie dieses Gerät nicht in einer unklimatisierten Umgebung oder einer höheren Lagertemperatur als 50°C; es könnte Schaden leiden.
8. Die Gehäuseöffnungen dienen der Luftkonvektion und schützen das Gerät vor Überhitzung. **BEDECKEN SIE DIE ÖFFNUNGEN NICHT!**
9. Überprüfen Sie die Spannung der Stromquelle, bevor Sie das Gerät an die Steckdose anschließen.
10. Verlegen Sie das Netzkabel so, dass man nicht darauf treten kann. Legen Sie nichts auf das Netzkabel. Das Netzkabel muss für das Gerät sowie die auf seinem elektrischen Kennschild angegebenen Strom- und Spannungswerte bemessen sein. Die Strom- und Spannungsbemessung des Netzkabels sollte höher als die auf dem Gerät angegebenen Strom- und Spannungswerte sein.
11. Alle Vorsichtshinweise und Warnungen auf dem Gerät sollten beachtet werden.
12. Falls das Gerät längere Zeit nicht benutzt wird, trennen Sie es vom Netz, um Beschädigung durch kurzfristige Überspannungen zu vermeiden.
13. Vergießen Sie niemals irgendeine Flüssigkeit in die Belüftungsöffnungen, dies kann Brand oder elektrischen Schlag verursachen.
14. Öffnen Sie das Gerät nie. Aus Sicherheitsgründen darf nur qualifiziertes Servicepersonal das Gerät öffnen.
15. Lassen Sie das Gerät von qualifiziertem Servicepersonal prüfen, falls sich einer der folgenden Vorfälle ergibt:
 - i. Das Netzkabel oder der Stecker ist beschädigt.
 - ii. Flüssigkeit ist in das Gerät eingedrungen.
 - iii. Das Gerät ist Feuchtigkeit ausgesetzt worden.
 - iv. Das Gerät arbeitet nicht richtig oder Sie können es nicht dem Benutzerhandbuch entsprechend zum arbeiten bringen.
 - v. Das Gerät ist gefallen und beschädigt.
 - vi. Falls das Gerät offensichtliche Bruchstellen aufweist.

16. Stellen Sie keine schweren Lasten auf das Gerät.
17. Stellen Sie sicher, dass alle KVM- und Schlitzschrauben des Gehäuses einwandfrei befestigt sind.
18. Die Einheit benutzt ein dreiadriges Erdungskabel, das mit einem dritten Anschlussstift zur Erdung ausgestattet ist, um elektrischen Schlag zu vermeiden. Annullieren Sie den Zweck dieses Anschlussstiftes nicht. Falls Ihre Steckdose diese Art Stecker nicht aufnimmt, ziehen Sie Ihren Elektriker zu Rate, um die veraltete Steckdose zu ersetzen.
19. **VORSICHT: DER COMPUTER IST MIT EINER BATTERIEBETRIEBENEN ECHTZEITUHR AUSGESTATTET: BEI FALSCEM BATTERIEERSATZ BESTEHT EXPLOSIONSGEFAHR. NUR DURCH GLEICHEN ODER GLEICHARTIGEN VOM HERSTELLER EMPFOHLENEN TYP ERSETZEN. GEBRAUCHTE BATTERIEN ENTSPRECHEND DEN ANWEISUNGEN DES HERSTELLERS ENTSORGEN.**

Chapter 11. Hardware Specifications



Below are the key hardware specifications for Clavister SG5500 Series installation.

Figure 11.1. Dimensions and Weight

Height x Width x Depth (mm)	177 x 426 x 670
Device weight	33 kg (80kg fully populated)
Device form Factor	4U
19" Rack Mountable ?	Yes
Redundant Hot-Swappable Power Supplies (AC)	7 x 100-240V 50 to 60 Hz AC

Figure 11.2. Regulatory and Safety Standards

Safety	CB, UL, TÜV
EMC	FCC class B CE EN 300 386:2003 Class B ETS 300 019-2-1 class 1.2 ETS 300 019-2-2 class 2.3 ETS 300 019-2-3 class 3.2

Figure 11.3. Environmental

Humidity	10% to 90% non-condensing
Operational Temperature	5° to 35°/55° C (depending on CPU version)

Further information

For complete product specifications refer to:

<http://www.clavister.com/products/>

Appendix A. SNMP Examples

This following examples are control messages that can be sent from an external SNMP workstation to the SG5500 Series CMM.

Alerts

```
// Alert Email receiver
SNMPv2-SMI::enterprises.17773.0.5.0.0.3.1 = STR: "alert@domain.com"

// MAC to log the trap event
SNMPv2-SMI::enterprises.17773.0.5.0.0.3.2 = STR: "FF FF FF FF FF FF"

// IP to log the trap eventq
SNMPv2-SMI::enterprises.17773.0.5.0.0.3.3 = IPAddr: 255.255.255.255
```

Power

```
//Chassis ID = 00 CMM Power up
enterprise.17773.0.5.0. 0.1.1.1.0 = 1

//Chassis ID = 00 Chassis power capacity = 100%
enterprise.17773.0.5.1. 0.1.1.2.0 = 100

//Chassis ID = 01 Chassis power interface no error
enterprise.17773.0.5.1. 1.1.1.3.0 = 0

//Chassis ID = 02 Chassis power interface error
enterprise.17773.0.5.1. 2.1.1.3.0 = 1
```

Temperature

```
//Chassis ID = 03 Chassis temperature[0] safe
enterprise.17773.0.5.1. 3.1.3.1.0 = 0

//Chassis ID = 04 Chassis temperature[1] warning
enterprise.17773.0.5.1. 4.1.3.1.1 = 1

//Chassis ID = 05 Chassis temperature[2] critical
enterprise.17773.0.5.1. 5.1.3.1.2 = 2

//Chassis ID = 06 Chassis temperature[3] safe
enterprise.17773.0.5.1. 6.1.3.1.3 = 0
```

Fans

```
//Chassis ID = 07 Chassis fanrpm[0] safe
enterprise.17773.0.5.1. 7.1.3.2.0 = 0

//Chassis ID = 08 Chassis fan rpm[1] warning
enterprise.17773.0.5.1. 8.1.3.2.1 = 1

//Chassis ID = 09 Chassis fanrpm[2] critical
enterprise.17773.0.5.1. 9.1.3.2.2 = 2

//Chassis ID = 10 Chassis fanrpm[3] safe
```

```
enterprise.17773.0.5.1.10.1.3.2.3 = 0

//Chassis ID = 11 Chassis fanrpm[4] warning
enterprise.17773.0.5.1.11.1.3.2.4 = 1

//Chassis ID = 12 Chassis fanrpm[5] critical
enterprise.17773.0.5.1.12.1.3.2.5 = 2

//Chassis ID = 13 Chassis fanrpm[6] safe
enterprise.17773.0.5.1.13.1.3.2.6 = 0

//Chassis ID = 14 Chassis fanrpm[7] warning
enterprise.17773.0.5.1.14.1.3.2.7 = 1
```

Voltage

```
//Chassis ID = 00 Chassis voltage[0] safe
enterprise.17773.0.5.1. 0.1.3.3.0 = 0

//Chassis ID = 01 Chassis voltage[1] warning
enterprise.17773.0.5.1. 1.1.3.3.1 = 1

//Chassis ID = 02 Chassis voltage[2] critical
enterprise.17773.0.5.1. 2.1.3.3.2 = 2
```

Blades

```
//Blade ID = 01 Blade power up
enterprise.17773.0.5.2. 1.1.1.1.0 = 1

//Blade ID = 02 Blade power down
enterprise.17773.0.5.2. 2.1.1.1.0 = 0

//Blade ID = 03 Blade insert
enterprise.17773.0.5.2. 3.1.2.1.0 = 1

//Blade ID = 04 Blade remove
enterprise.17773.0.5.2. 4.1.2.1.0 = 0

//Blade ID = 05 Blade temperature safe
enterprise.17773.0.5.2. 5.1.3.1.0 = 0

//Blade ID = 06 Blade fanrpm warning
enterprise.17773.0.5.2. 6.1.3.2.0 = 1

//Blade ID = 07 Blade vcore critical
enterprise.17773.0.5.2. 7.1.3.3.0 = 2
```

Alphabetical Index

A

abbreviations, 5
account management, 50
alert notification, 46
alter settings, 39

B

blade status, 38

C

chassis
 id assignment, 26
chassis control, 41
chassis management module, 14
 standby mode, 31
chassis rail attachment, 23
chassis settings, 45
chassis version, 44
CMM (see chassis management module)
console set-up, 32

D

daisy chaining, 27

E

environment, 20

H

hardware
 components, 10
 specifications, 65
hardware layout
 rear, 13
health monitor, 37
hot-swapping, 53
 chassis management module, 57
 cooling fan tray, 58
 power supply, 55
 rear transition module, 57
 SBM, 53

I

installation, 20

L

login
 remote management, 36
log reference guide,

M

managing cables, 21
monitoring hardware, 37
mounting rails, 23

N

network settings, 46

P

powering off, 31
powering on, 30
power supply unit, 55
 inlets, 13
pre-loading standby SBMs, 53
product overview, 8
PSU (see power supply unit)

R

rear transition module, 17
RTM (see rear transition module)

S

safety information
 in english, 60
 in german, 62
SBM (see secure blade module)
secure blade module
 control, 40
 installing, 25
 overview, 10
 port, buttons and LEDs, 11
 slot positions, 11
server room
 layout, 21
 securing, 21
SNMP
 enabling,
 traps, 46
snmp
 examples, 66

U

unpacking, 9
upgrading firmware, 47

W

web-interface, 36, 36
 adding an account, 50
 changing a password, 51
 default IP address, 36
 default password, 36

V

version information, 43